

USR-LG220 User Manual

File Version: V1.0.6.01



Contents

USR-LG220 User Manual.....	1
Features	3
1.Get Start	4
1.1.Product introduction	4
1.2.Basic parameters	4
1.3.Application diagram.....	5
1.4.Hardware design	5
1.4.1.Interface.....	5
1.4.2.LED	5
1.4.3.Dimension.....	6
2.Product function.....	7
2.1.APN configuration.....	7
2.2.Work mode	7
2.2.1.Node active reporting mode	8
2.2.2.Polling waking mode	9
2.3.Connect to server	11
2.3.1.MQTT server	11
2.3.2.Socket connection.....	11
2.4.Other LoRa configuration.....	12
2.4.1.Other concentrator configuration	12
2.4.2.Node management.....	13
2.5.Features	14
2.5.1.4G interface	14
2.5.2.WAN interface	15
2.5.3.WiFi interface	17
2.5.4.Network Diagnosis.....	19
2.5.5.Upgrade firmware	20
2.5.6.Restart.....	20
3.Configuration	22
3.1.Configuration procedure	22
3.1.1.Web Server.....	22
4.Contact Us.....	23
5.Disclaimer	23
6.Update History	23

Features

- Adopt LoRa private protocol.
- Smart Ad-Hoc Network.
- Adopt TDM technology which has low interference.,
- Support WAN interface and SIM card slot to provide various networking method.
- Support WiFi interface.
- Support VPN(PPTP/L2TP), PPPOE, DHCP and static IP.
- Support various LED function.
- Support restore default settings by hardware.
- Support MQTT/socket server connection.
- Support long-distance transmission and transmission distance can be 2000 meters.

1. Get Start

If user has any question, please submit it back to customer center: <http://h.usriot.com>.

1.1. Product introduction

USR-LG220 is concentrator based on low-power consumption and WAN LoRa private protocol. LG220 can realize networking between concentrator and LoRa module, communication between concentrator and server by USR private protocol.

USR-LG220 supports one wired WAN interface, WiFi interface and 4G interface to realize various networking method. LoRa private protocol can make communication more simple, more secure and more reliable. User can realize communication by configuring concentrator and LoRa module without caring about protocol.

Model	Frequency
USR-LG220-L-C	398Mhz~525Mhz
USR-LG220-H-C	803Mhz~930Mhz

1.2. Basic parameters

Item	Description	
Product name	USR-LG220	LoRa Gateway
Ethernet interface	WAN interface	One
WiFi parameters	Standard	802.11b/g/n
	Antenna	WiFi antenna
	Distance	120m in open area
Four LoRa channels: One administration channel and three communication channels	Protocol	USR private protocol
	Frequency band	L: 398MHz~525MHz H: 803Mhz ~930Mhz
	Transmitting power	Maximum transmitting power 20dBm
	Antenna	470~510Mhz antenna
4G parameters	SIM/USIM card	Standard six pin SIM card interface and support 3V/1.8V SIM card
	Antenna	5dbi stick antenna
Button	Reload	Restore default settings
LED	Status LED	Power, WiFi, 2G/3G/4G, WAN interface, TX/RX
Temperature	Working	-20℃~+70℃

	temperature	
	Storage temperature	-40℃~+75℃
Humidity	Working humidity	5%~95%RH
	Storage humidity	1%~95%RH
Power supply	Voltage	DC 5~36V(Standard: 12V/1A)
	Power consumption	5V/0.6A, 12V/0.3A, 36V/0.07A

Figure 1 Basic parameters

1.3.Application diagram

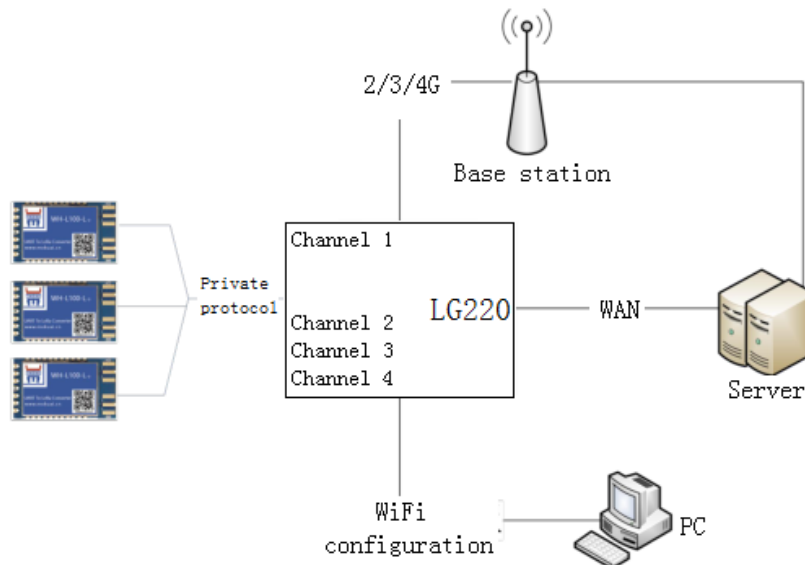
Figure 2 Application diagram

1.4.Hardware design

1.4.1.Interface

Interface	Description
DC power supply socket	Range from 5V to 36V. Standard power supply socket: 5.5*2.1mm
DC power supply terminal	Range from 5V to 36V.
WAN interface	Wired WAN interface. 10/100Mbps and support Auto MDI/MDIX
USB interface	Reserved
LED	Refer to 1.4.2.LED
SIM card slot	One SIM card slot
Reload button	Press over 5 seconds and release to restore default settings
LoRa antenna	Four LoRa antennas
WiFi antenna	One WiFi antennas
3G/4G antenna	One 4G antenna

Figure 3 Interface

1.4.2.LED

LED	Description
-----	-------------

PWR	Light after powering the module.
WLAN	Light after WiFi starting successfully.
WAN	Light after inserting cable. Blink when there are data transmission.
LoRa	Light when there are data transmission between concentrator and LoRa module.
2G	Light when LTE module works in 2G mode.
3G	Light when LTE module works in 3G mode.
RSSI(1~4)	More RSSI LED light means stronger RSSI.

Figure 4 LED

Note: When LTE module works in 4G mode, 2G and 3G LED will both light.

1.4.3.Dimension

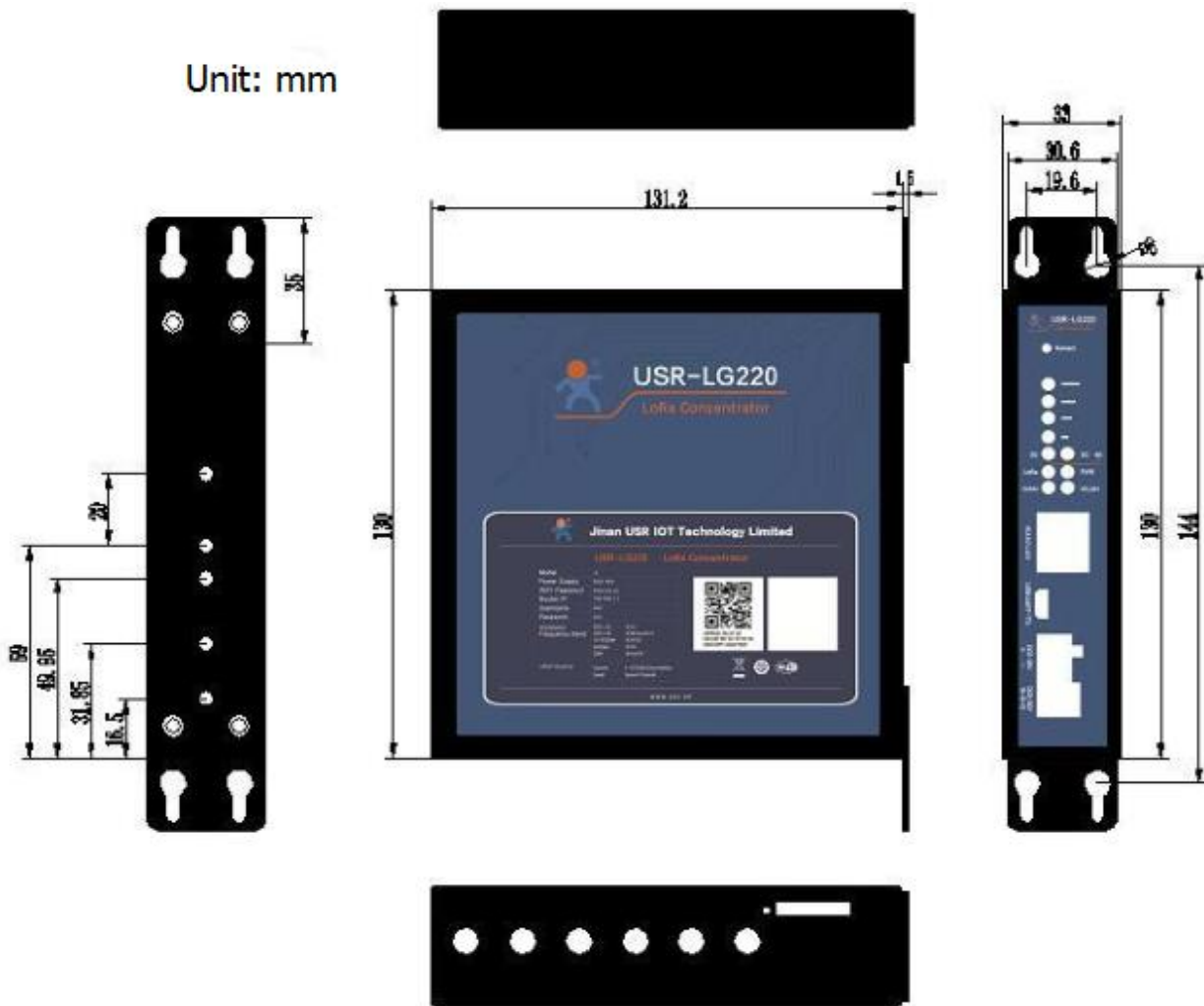

Figure 5 Dimension

2.Product function

LG220 main function: Make LG220 concentrator and LoRa modules make up a communication network by USR private protocol; realize data transmitting and receiving data from LoRa node, then LG220 will upload valid data to server.

2.1.APN configuration

After inserting SIM card, user needs to configure APN settings to make LG220 connect to 4G network firstly. User can configure APN configuration by Web Server as follow:

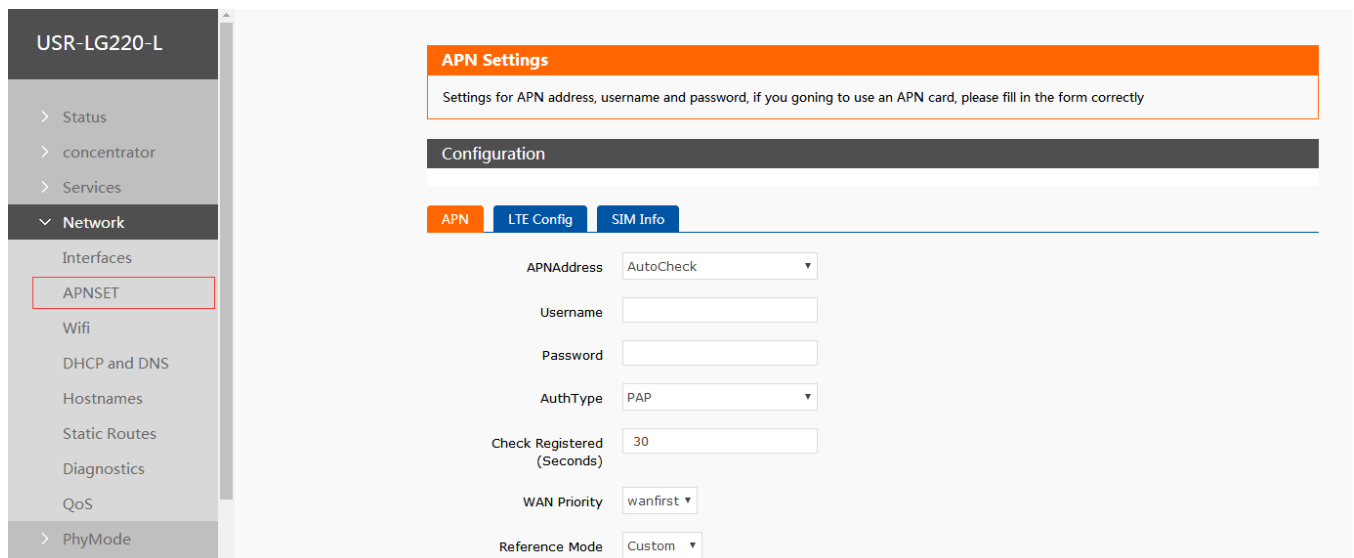

The screenshot shows the web interface for USR-LG220-L. On the left is a navigation menu with 'APNSET' highlighted under the 'Network' section. The main content area is titled 'APN Settings' and includes a note: 'Settings for APN address, username and password, if you going to use an APN card, please fill in the form correctly'. Below this is a 'Configuration' section with three tabs: 'APN' (selected), 'LTE Config', and 'SIM Info'. The 'APN' tab contains the following fields:

- APNAddress: AutoCheck (dropdown)
- Username: (text input)
- Password: (text input)
- AuthType: PAP (dropdown)
- Check Registered (Seconds): 30 (text input)
- WAN Priority: wanfirst (dropdown)
- Reference Mode: Custom (dropdown)

Figure 6 APN configuration

2.2.Work mode

USR-LG220 has two work modes:

- Node active reporting mode
- Polling waking mode

Note: In both two work modes, three conditions must be met to make LoRa module access concentrator network:

- Concentrator administration channel(channel 1) and LoRa module have same channel.
- Concentrator administration channel(channel 1) and LoRa module have same rate.
- Concentrator and LoRa module have same application ID.

2.2.1. Node active reporting mode

Node active reporting mode: After configuring LG220 into this mode, LoRa modules which access LG220 network will enter active reporting mode. LG220 will return response automatically after receiving data from LoRa node module and will also upload valid data to server.

- In this mode, LG220 will enter listening status after powering on. Matched LoRa modules will send accessing network information to LG220 automatically after powering on. After LG220 receiving these accessing network information by administration channel(channel 1), LG220 will distribute these LoRa modules to three communication channels(channel 2, 3, 4) in sequence, then return configuration data of accessing network to these LoRa modules immediately and save these LoRa node modules information into database.
- LoRa modules will change channel and rate automatically according to configuration data of accessing network and match communication channel(channel 2, 3, 4), then report data to LG220 periodically according to configuration.

User can configure LG220 into this mode by Web Server as follows(Three communication channels all need to configured into this mode):

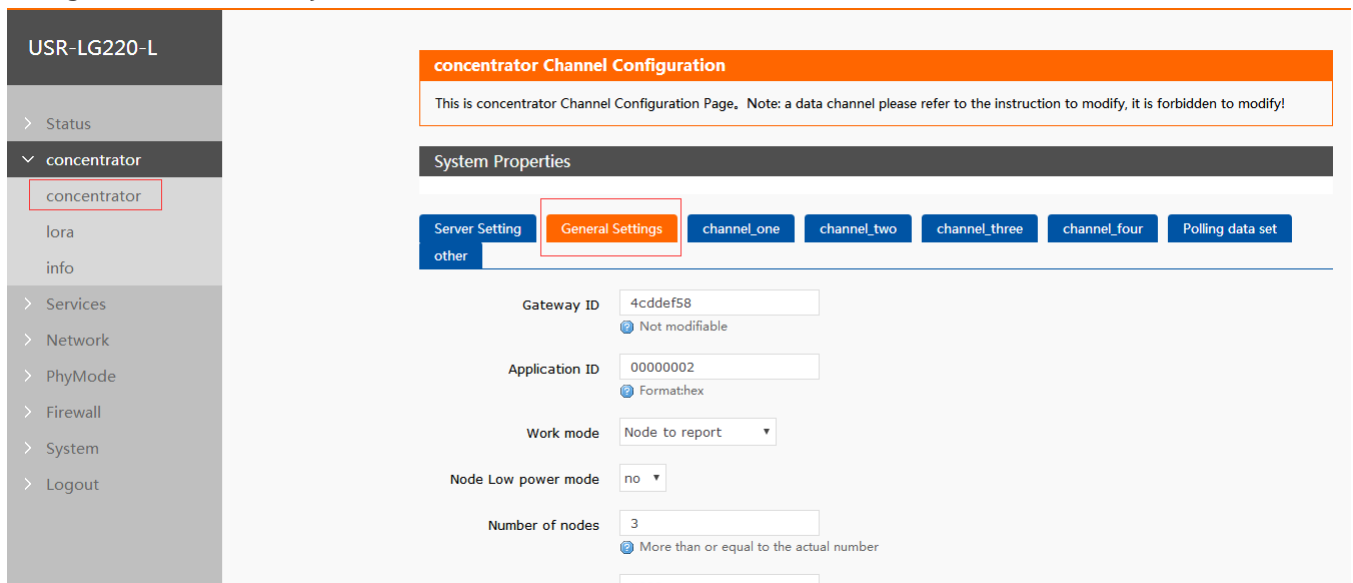
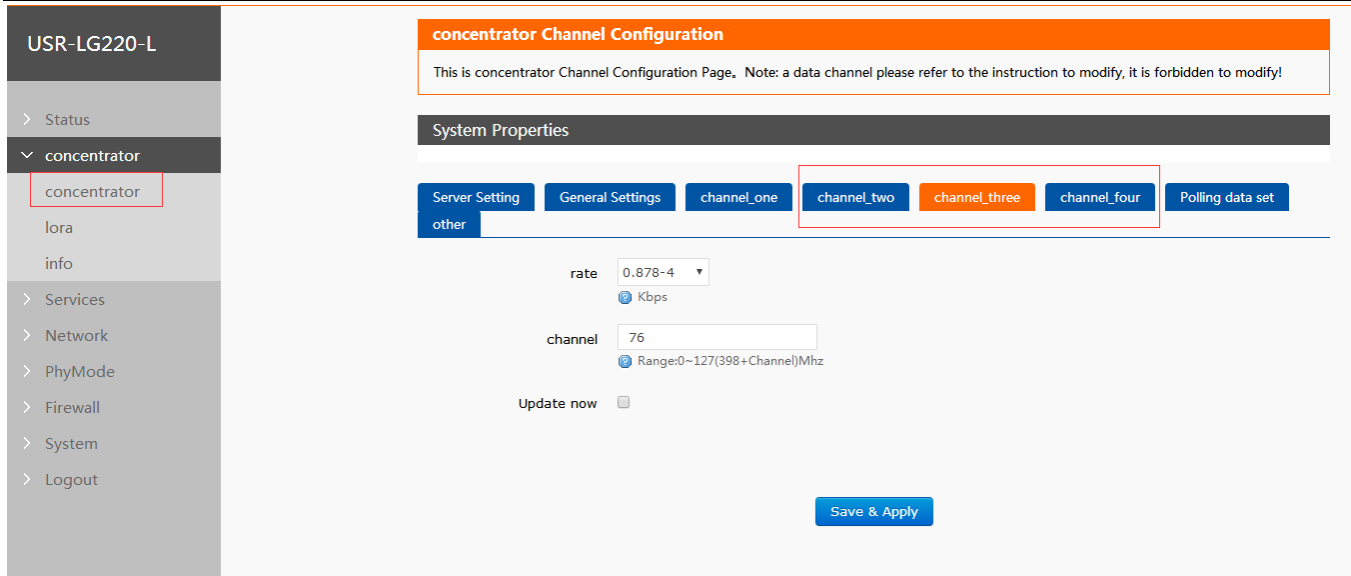

Figure 7 Node active reporting mode general settings

- Application ID: In HEX format and user should configure this to be same as LoRa node module which access to LG220 network.
- Gateway ID: LG220 unique identification ID and can't be changed.
- Number of nodes: Reserved accessing nodes. Number of nodes should be equal or greater than actual accessing node.
- Adjacent Nodes Time slot: Idle time from last node finish transmission to current node start transmission. This parameter is to prevent reporting data interference between adjacent node and supports at most 65535ms.



concentrator Channel Configuration

This is concentrator Channel Configuration Page. Note: a data channel please refer to the instruction to modify, it is forbidden to modify!

System Properties

Server Setting | General Settings | channel_one | **channel_two** | channel_three | channel_four | Polling data set

other

rate: 0.878-4
 Kbps

channel: 76
Range:0~127(398+Channel)Mhz

Update now

Save & Apply

Figure 8 Node active reporting mode channel settings

Note: If user chooses 'Update now' and click 'Save&Apply', configuration will take effect after 10 seconds.

2.2.2.Polling waking mode

Polling waking mode: After configuring LG220 into this mode, LoRa modules which access LG220 network will enter passive waking mode. LG220 will transmit lead code(Duration of lead code is same as waking period) to wake up all LoRa node modules which connect to LG220 network according to Web Server configuration, then LG220 will transmit data to LoRa node modules; after transmitting data, LG220 will transmit next data immediately if LG220 receives response data from LoRa node modules, otherwise LG220 will transmit next data after receiving time overtime.

- After configuring LG220 into polling waking mode and configuring related parameters, LG220 will enter listing status. When LoRa node module access LG220 network, LG220 will respond accessing network information and save node information. When accessing network node is greater than 0 or accessing network node has existed in database, LG220 will transmit waking data to wake up LoRa node module periodically according to waking period, polling period and polling timeout time.
- After receiving data from LG220, LoRa node module will take corresponding action and return related data to achieve one time data transmission, then node will enter sleep mode and wait LG220 transmit next waking data in next period. In this mode, user can configure at most 16 waking data.

User can configure LG220 into this mode by Web Server as follows(Three communication channels all need to configured into this mode and same rate):

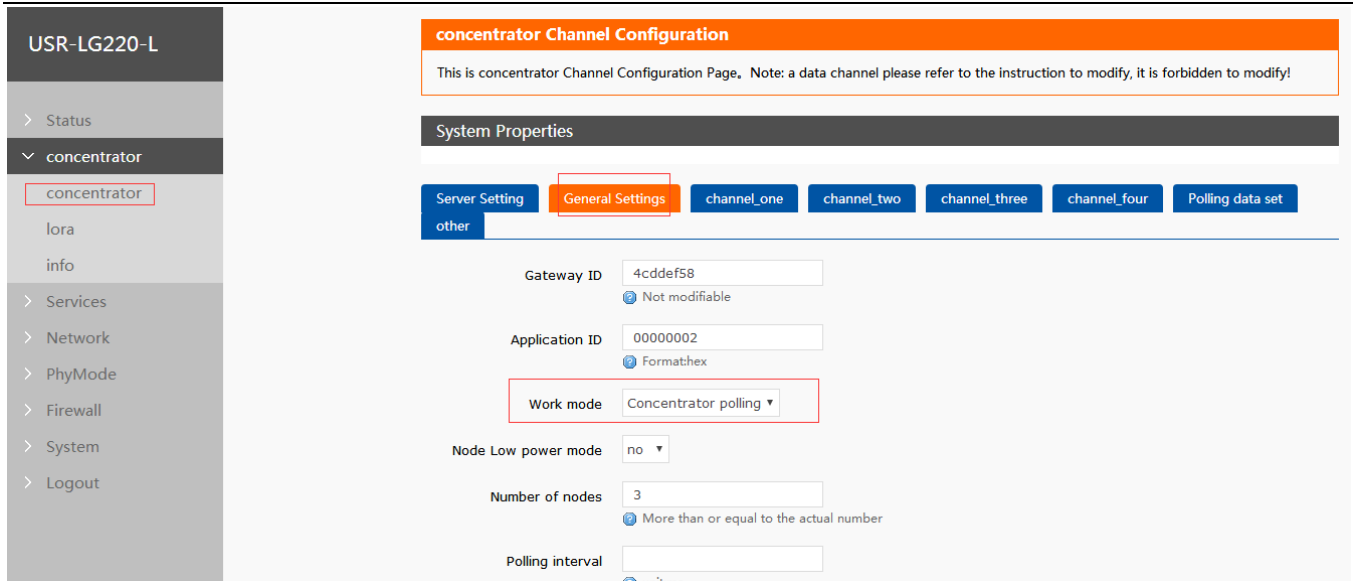

Figure 9 Polling waking mode general settings

- Concentrator Receive timeout: Timeout time to wait node return data after concentrator transmitting polling data and support at most 65535ms.
- Polling interval: Interval from finish polling all nodes to start next polling and support at most 10 days. Unit ms.

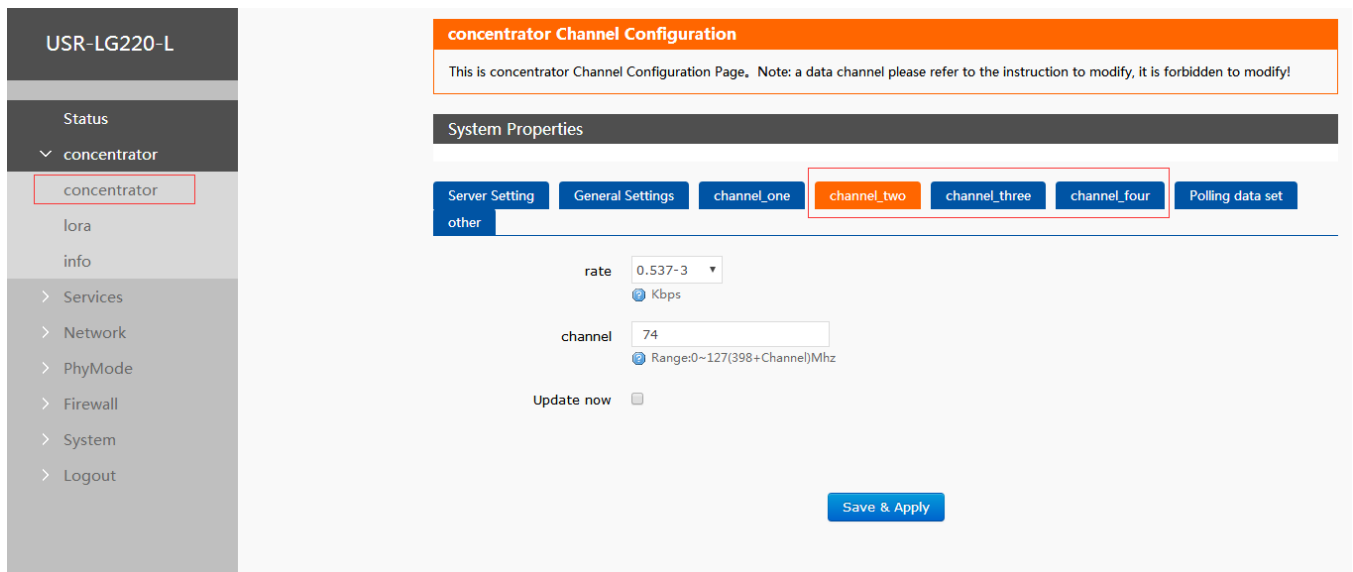

Figure 10 Polling waking mode channel settings

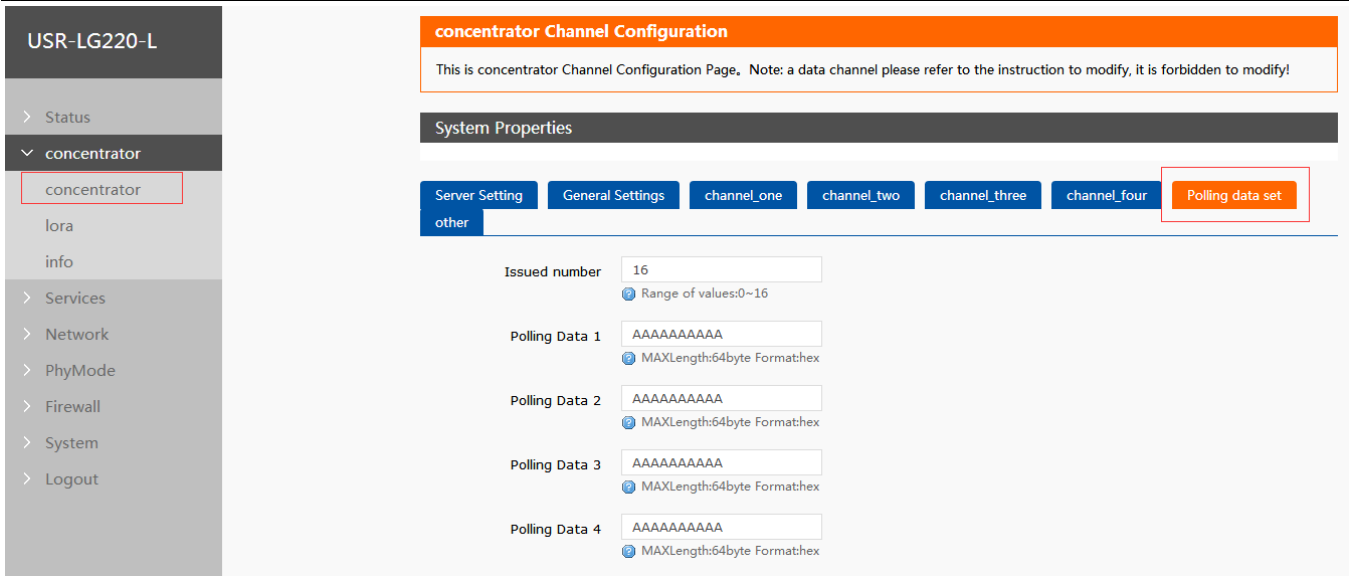

Figure 11 polling data settings

2.3.Connect to server

2.3.1.MQTT server

User can configure LG220 to connect to MQTT server by Web Server as follow:

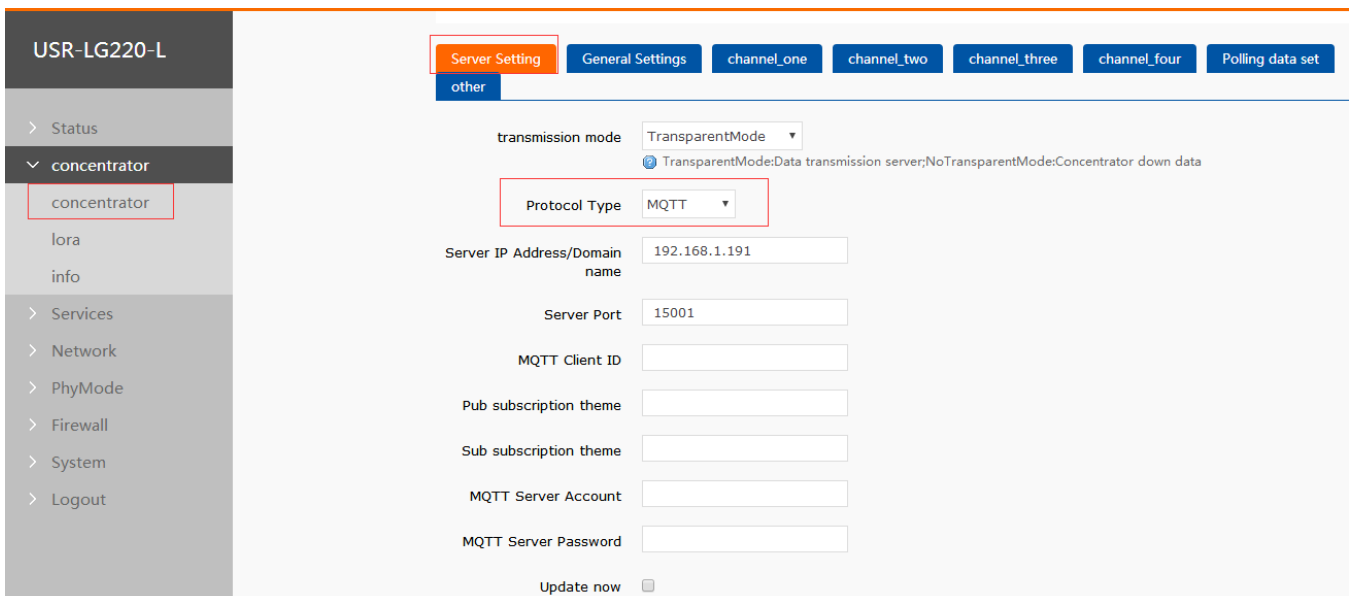
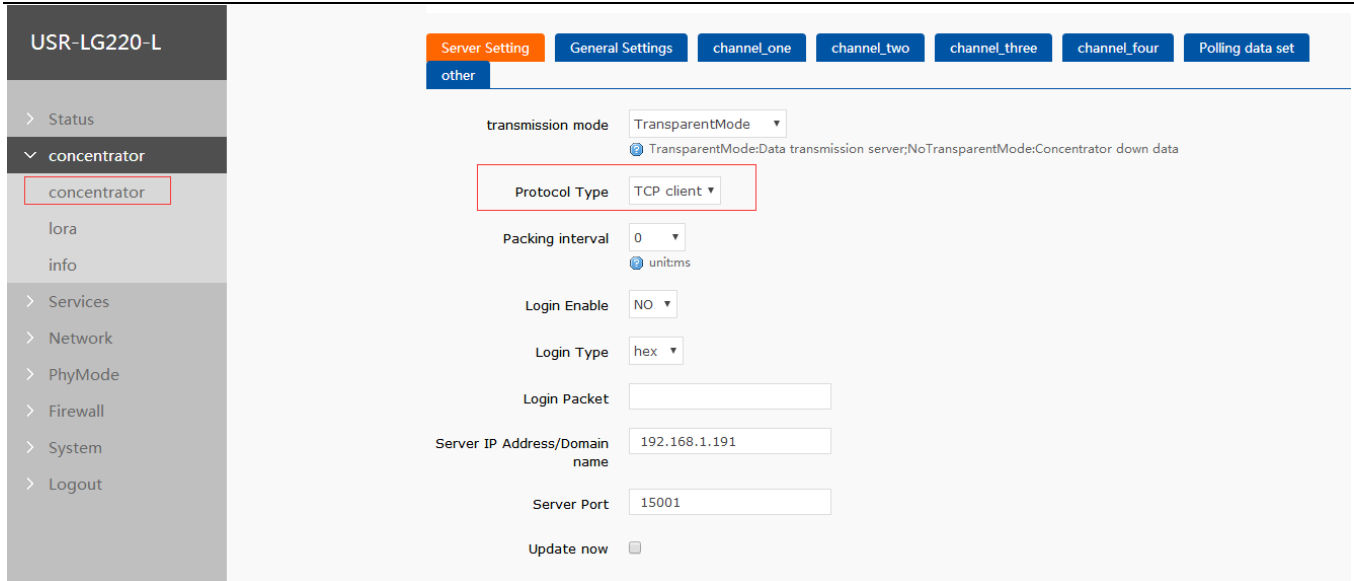

Figure 12 MQTT Server configuration

- MQTT Client ID: Registration Code on the surface label of LG220.

2.3.2.Socket connection

User can configure LG220 to connect to socket server by Web Server as follow:



The screenshot shows the 'other' settings page for the USR-LG220-L device. The left sidebar contains a navigation menu with 'concentrator' selected. The main content area has several tabs: 'Server Setting' (highlighted), 'General Settings', 'channel_one', 'channel_two', 'channel_three', 'channel_four', and 'Polling data set'. Below the tabs, the following settings are visible:

- transmission mode: TransparentMode (dropdown)
- Protocol Type: TCP client (dropdown, highlighted with a red box)
- Packing interval: 0 (dropdown)
- Login Enable: NO (dropdown)
- Login Type: hex (dropdown)
- Login Packet: (empty text input)
- Server IP Address/Domain name: 192.168.1.191 (text input)
- Server Port: 15001 (text input)
- Update now:

Figure 13 Socket connection configuration

- Protocol Type: Support TCP Client and UDP protocol
- Packing interval: Time interval of adjacent data packet which will be uploaded to server.

2.4. Other LoRa configuration

2.4.1. Other concentrator configuration

User can configure concentrator other settings as follow:

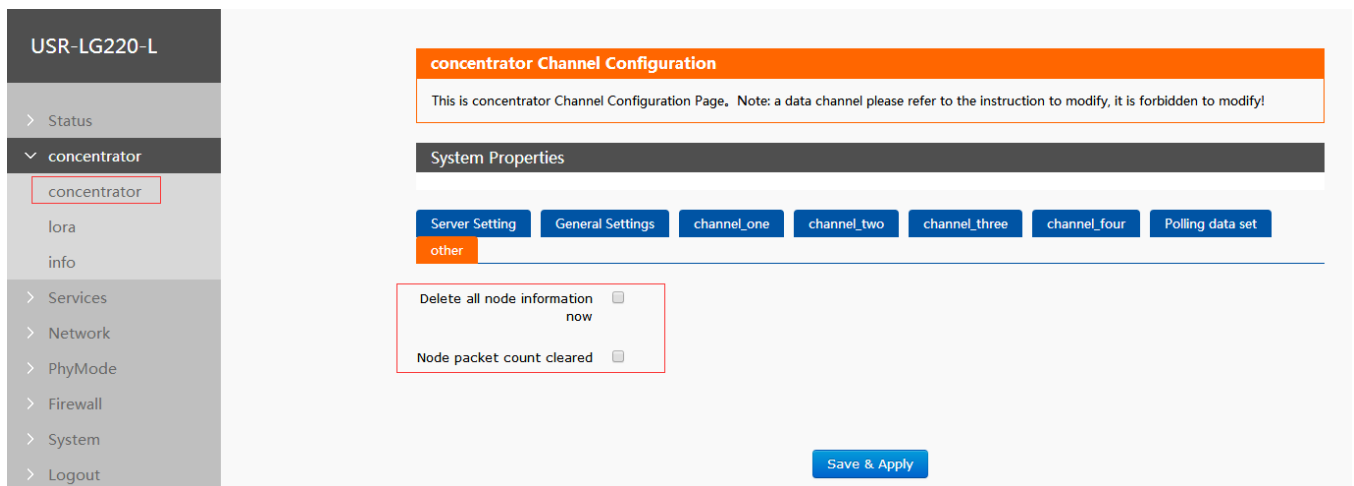

The screenshot shows the 'concentrator Channel Configuration' page. The left sidebar is the same as in Figure 13. The main content area has a title bar 'concentrator Channel Configuration' and a warning message: 'This is concentrator Channel Configuration Page, Note: a data channel please refer to the instruction to modify, it is forbidden to modify!'. Below this is a 'System Properties' section with tabs: 'Server Setting', 'General Settings', 'channel_one', 'channel_two', 'channel_three', 'channel_four', and 'Polling data set'. The 'other' tab is selected. The settings are:

- Delete all node information now:
- Node packet count cleared:

A 'Save & Apply' button is located at the bottom right of the settings area.

Figure 14 Concentrator other settings

- Delete all node information now: Delete all node information which have accessed to LG220 network. User needs to restart LG220 and LoRa node module will access to LG220 network again after deleting.
- Node packet count cleared: Clear the node data receiving/transmitting count in the following **Figure 15 Concentrator information** and recount.

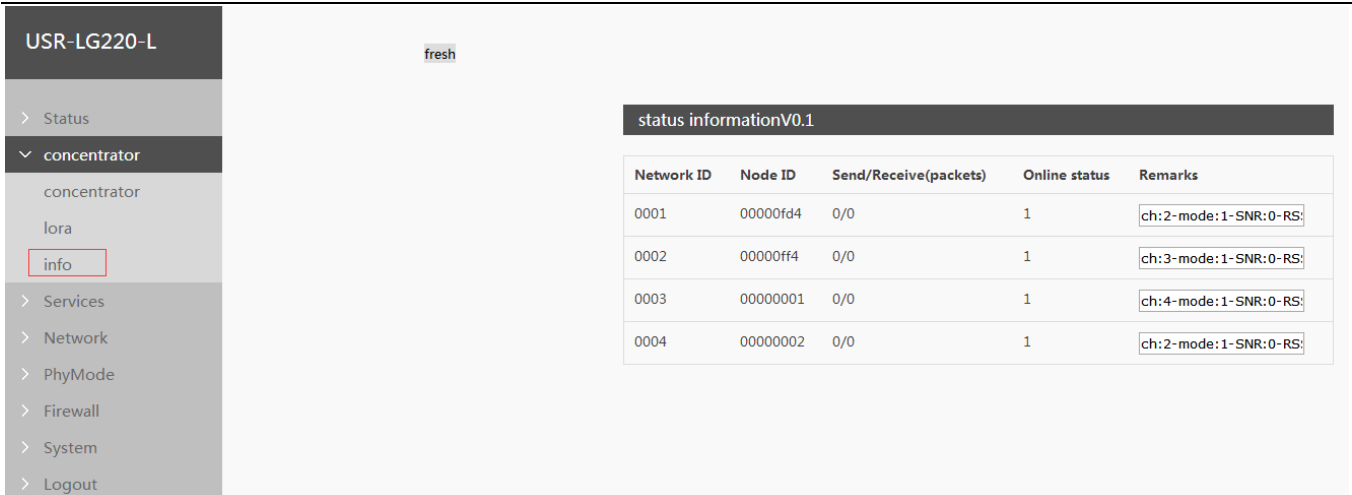

The screenshot shows the 'concentrator' menu with 'info' selected. The main content area displays 'status informationV0.1' and a table with the following data:

Network ID	Node ID	Send/Receive(packets)	Online status	Remarks
0001	00000fd4	0/0	1	ch:2-mode:1-SNR:0-RS:
0002	00000ff4	0/0	1	ch:3-mode:1-SNR:0-RS:
0003	00000001	0/0	1	ch:4-mode:1-SNR:0-RS:
0004	00000002	0/0	1	ch:2-mode:1-SNR:0-RS:

Figure 15 Concentrator information

This web displays status of the current nodes in LG220 network and these parameters will update every 10 seconds.

- In node active reporting mode, this web will only display receiving packets.
- In 'Remarks' line: ch: channel; mode: 1 means node active reporting mode and 2 means polling waking mode.
- User can make customization according to own needs.

2.4.2. Node management

User can configure node management parameters as follow:

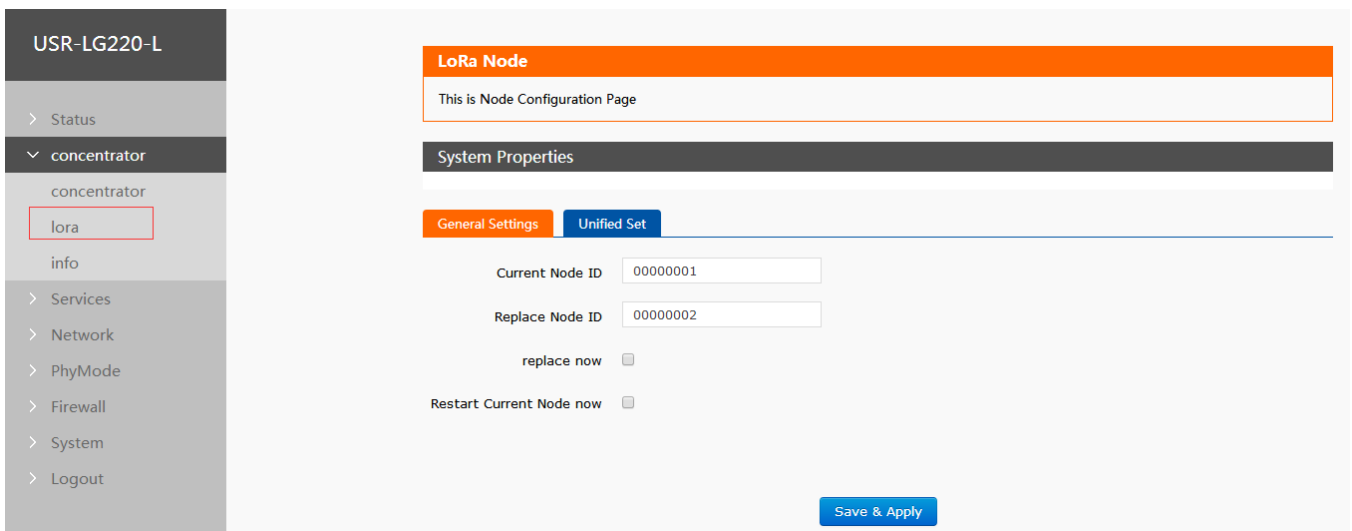

The screenshot shows the 'LoRa Node' configuration page. Under 'System Properties', the 'General Settings' tab is active. It contains the following fields and options:

- Current Node ID:
- Replace Node ID:
- replace now:
- Restart Current Node now:

A 'Save & Apply' button is located at the bottom right of the configuration area.

Figure 16 LoRa Node general settings

- replace now: Replace 'Current Node ID' node to 'Replace Node ID' node. ID should in HEX format and less than 32 bytes.
- Restart Current Node now: Restart 'Current Node ID' node.

If users chooses both 'replace now' and 'Restart Current Node now', LG220 will executive 'replace now' command.

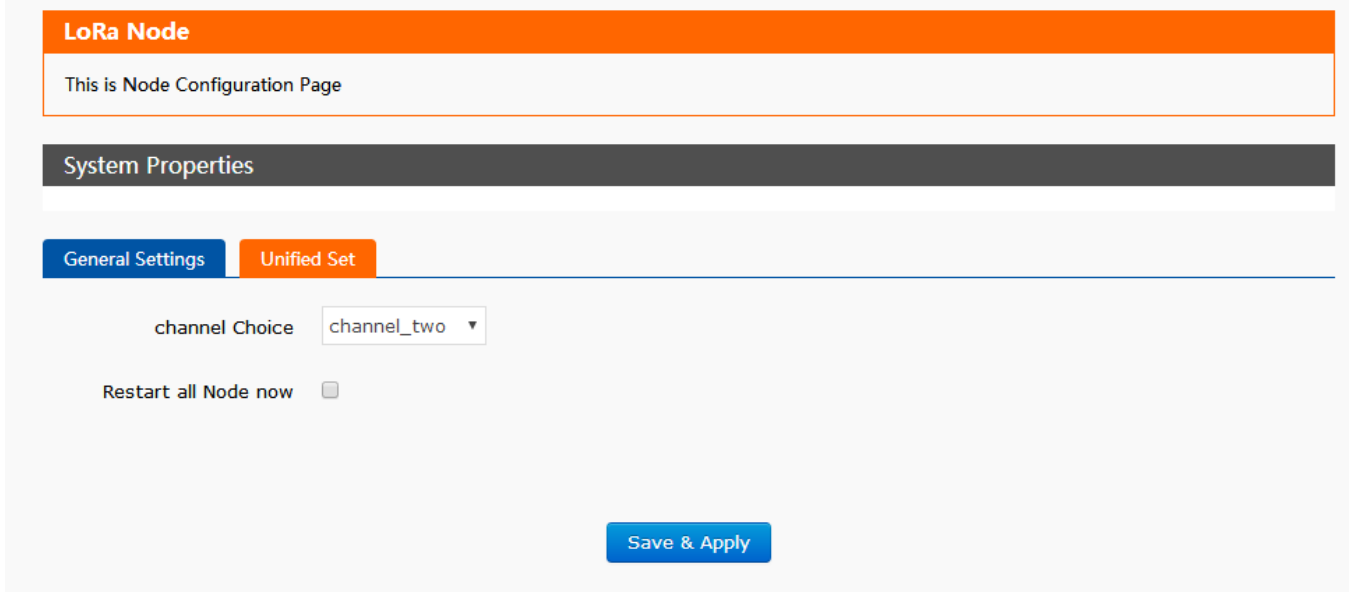

Figure 17 LoRa node unified settings

User can restart all nodes in one of three communication channels.

2.5.Features

2.5.1.4G interface

LG220 supports one 4G interface to access internet. Functional diagram as follow:

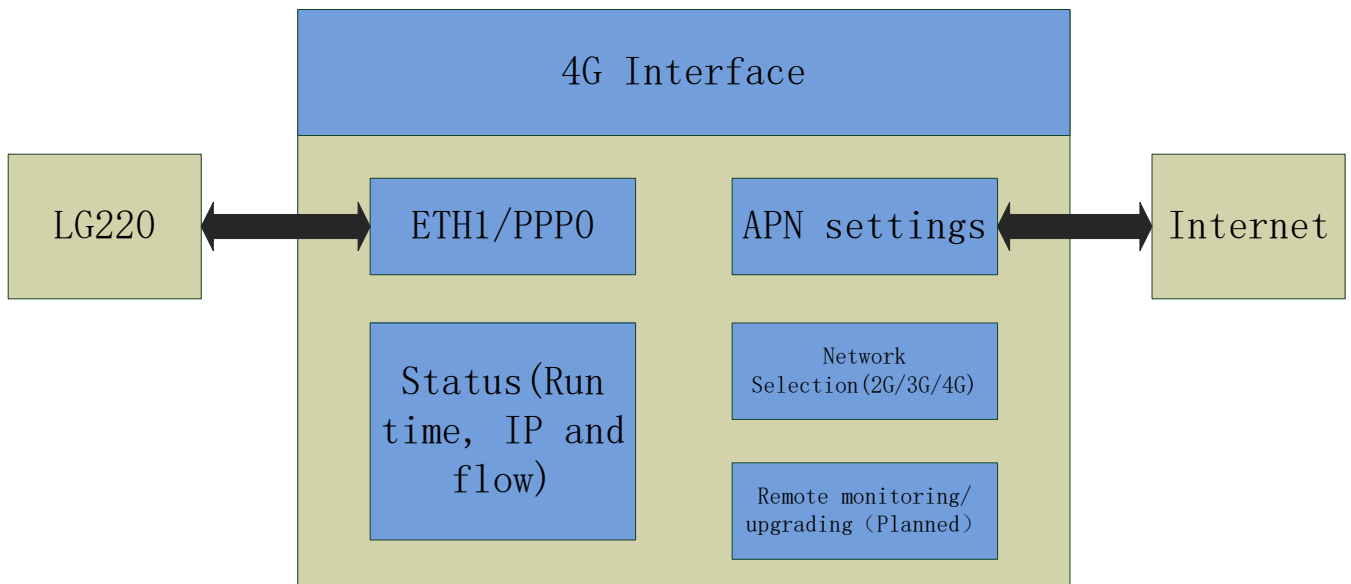
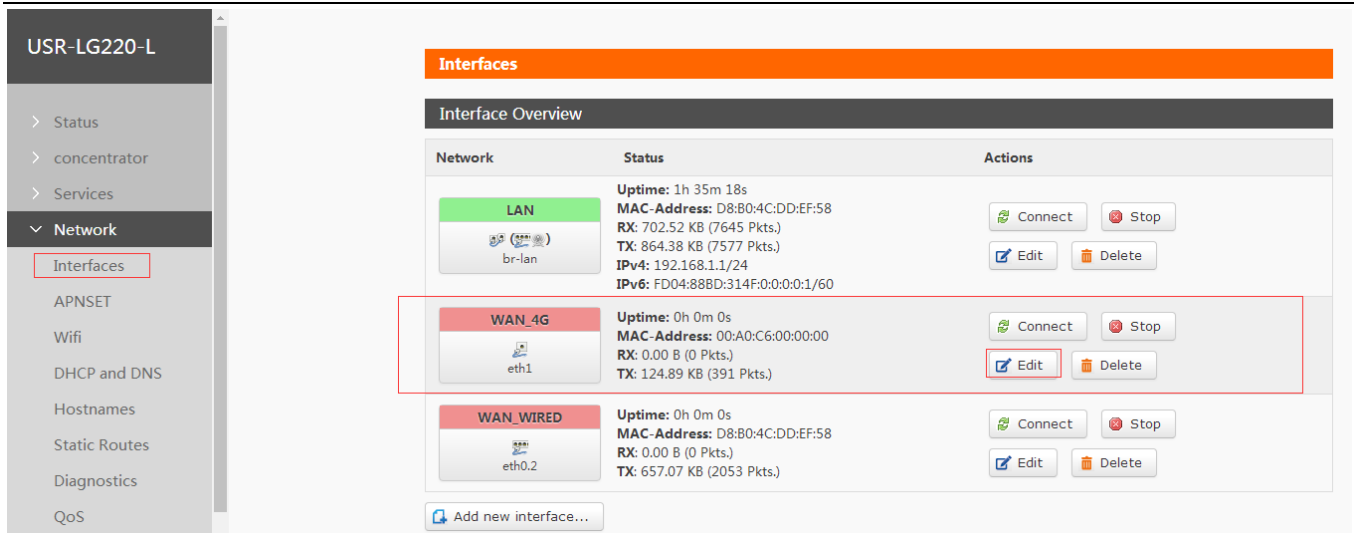

Figure 18 4G interface functional diagram

User can configure 4G interface by Web Server as follow:



Interfaces

Interface Overview

Network	Status	Actions
LAN br-lan	Uptime: 1h 35m 18s MAC-Address: D8:B0:4C:DD:EF:58 RX: 702.52 KB (7645 Pkts.) TX: 864.38 KB (7577 Pkts.) IPv4: 192.168.1.1/24 IPv6: FD04:88BD:314F:0:0:0:1/60	Connect Stop Edit Delete
WAN_4G eth1	Uptime: 0h 0m 0s MAC-Address: 00:A0:C6:00:00:00 RX: 0.00 B (0 Pkts.) TX: 124.89 KB (391 Pkts.)	Connect Stop Edit Delete
WAN_WIRED eth0.2	Uptime: 0h 0m 0s MAC-Address: D8:B0:4C:DD:EF:58 RX: 0.00 B (0 Pkts.) TX: 657.07 KB (2053 Pkts.)	Connect Stop Edit Delete

Add new interface...

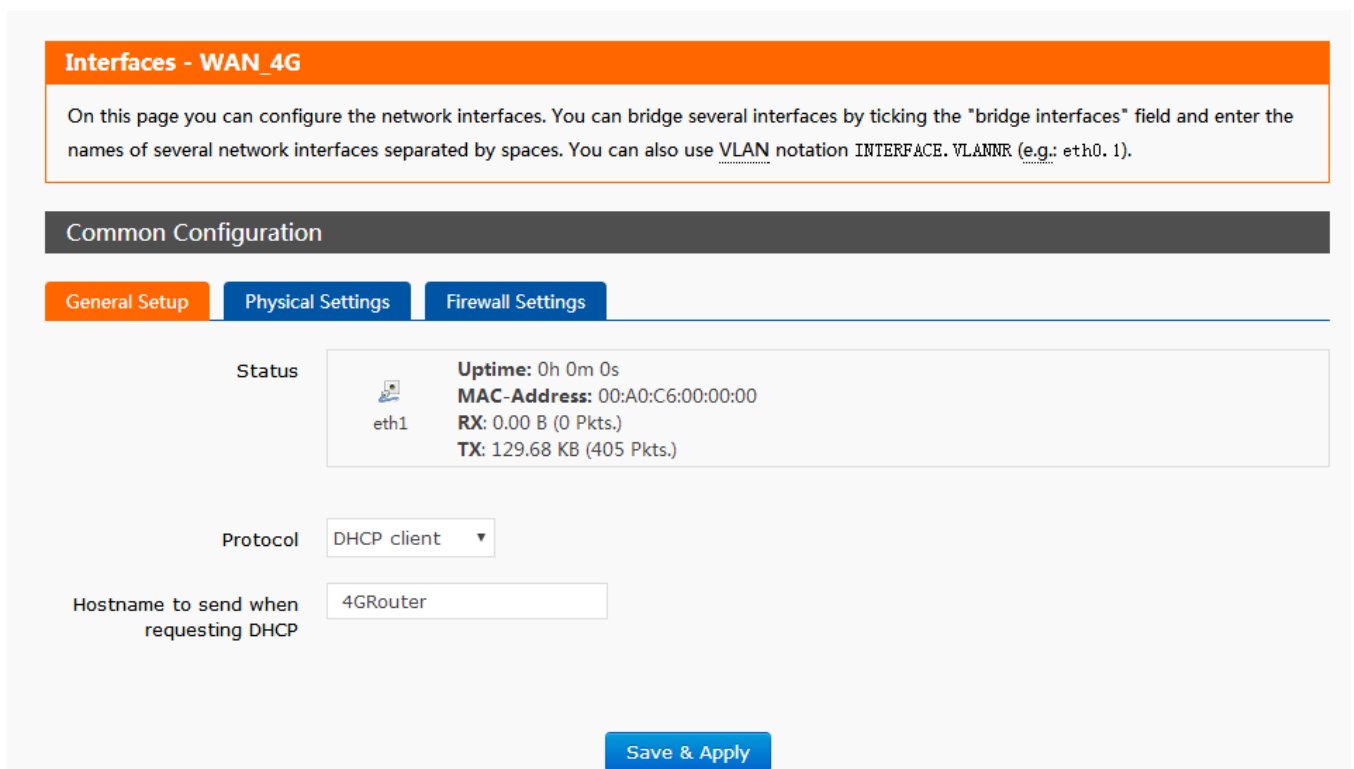

Interfaces - WAN_4G

On this page you can configure the network interfaces. You can bridge several interfaces by ticking the "bridge interfaces" field and enter the names of several network interfaces separated by spaces. You can also use VLAN notation INTERFACE.VLANNR (e.g.: eth0. 1).

Common Configuration

General Setup Physical Settings Firewall Settings

Status
eth1
Uptime: 0h 0m 0s
MAC-Address: 00:A0:C6:00:00:00
RX: 0.00 B (0 Pkts.)
TX: 129.68 KB (405 Pkts.)

Protocol: DHCP client

Hostname to send when requesting DHCP: 4GRouter

Save & Apply

Figure 19 4G interface settings

Note: LG220 will consider wired WAN interface as priority, then is 4G network. And when user configures 4G interface, please keep 4G interface protocol in default setting,

2.5.2.WAN interface

User can configure WAN interface by Web Server as follow:

Figure 20 WAN interface settings

Note: LG220 supports one wired WAN interface. WAN interface supports DHCP Client mode and Static IP mode, and default setting is DHCP Client mode.

WAN interface can also switch to LAN interface and user can switch it by Web Server as follow:

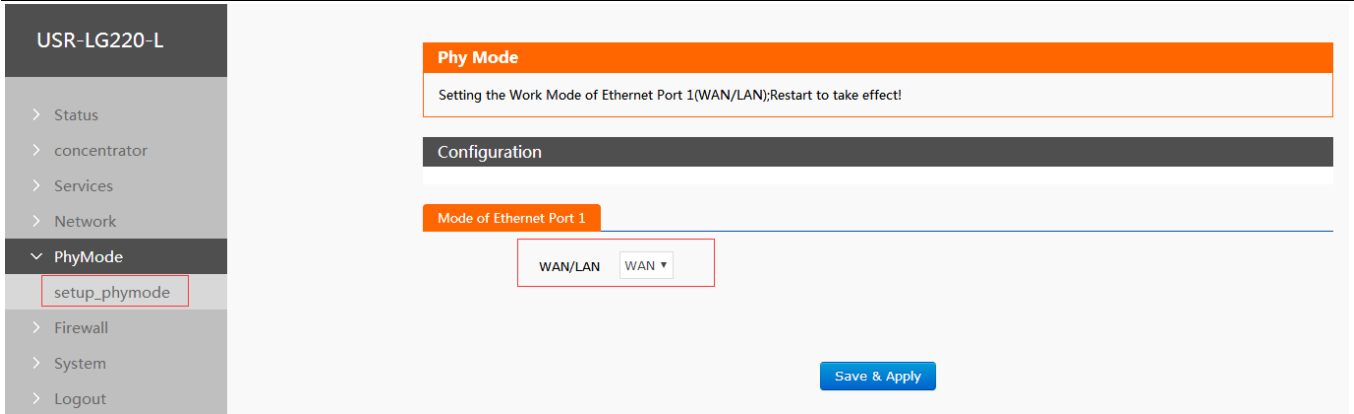

Figure 21 Switch between WAN/LAN

2.5.3.WiFi interface

LG220 WiFi interface functional diagram as follow:

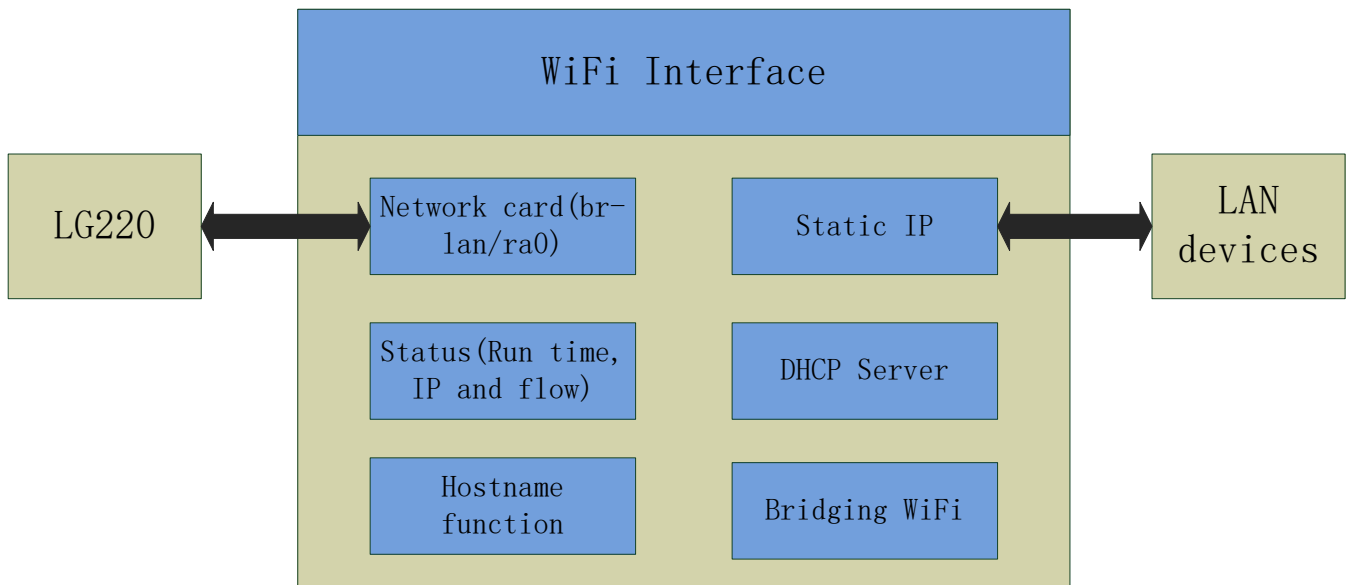

Figure 22 WiFi interface functional diagram

Note:

- LG220 is an AP module and other wireless device can connect to LG220 WiFi interface.
- LG220 supports at most 24 STA device connection.
- Maximum coverage of WiFi is 120m in open area.

Default parameters as follows:

SSID	USR-LG220 -L-XXXX(XXXX is MAC address)
Password	www.usr.cn
Channel	Auto
Bandwidth	40MHz
Encryption Mode	WPA2-PSK

Figure 23 WiFi interface default parameters

Configure WiFi interface on Web Server as follow:

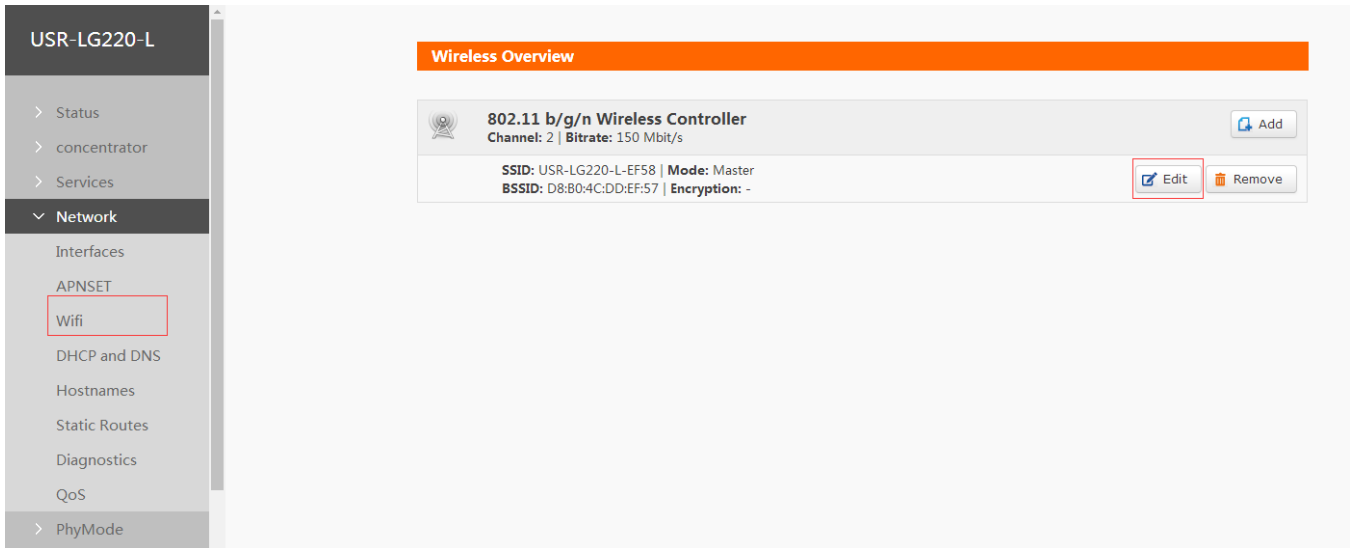

Figure 24 WiFi interface settings

User can configure SSID on Web Server as follow:

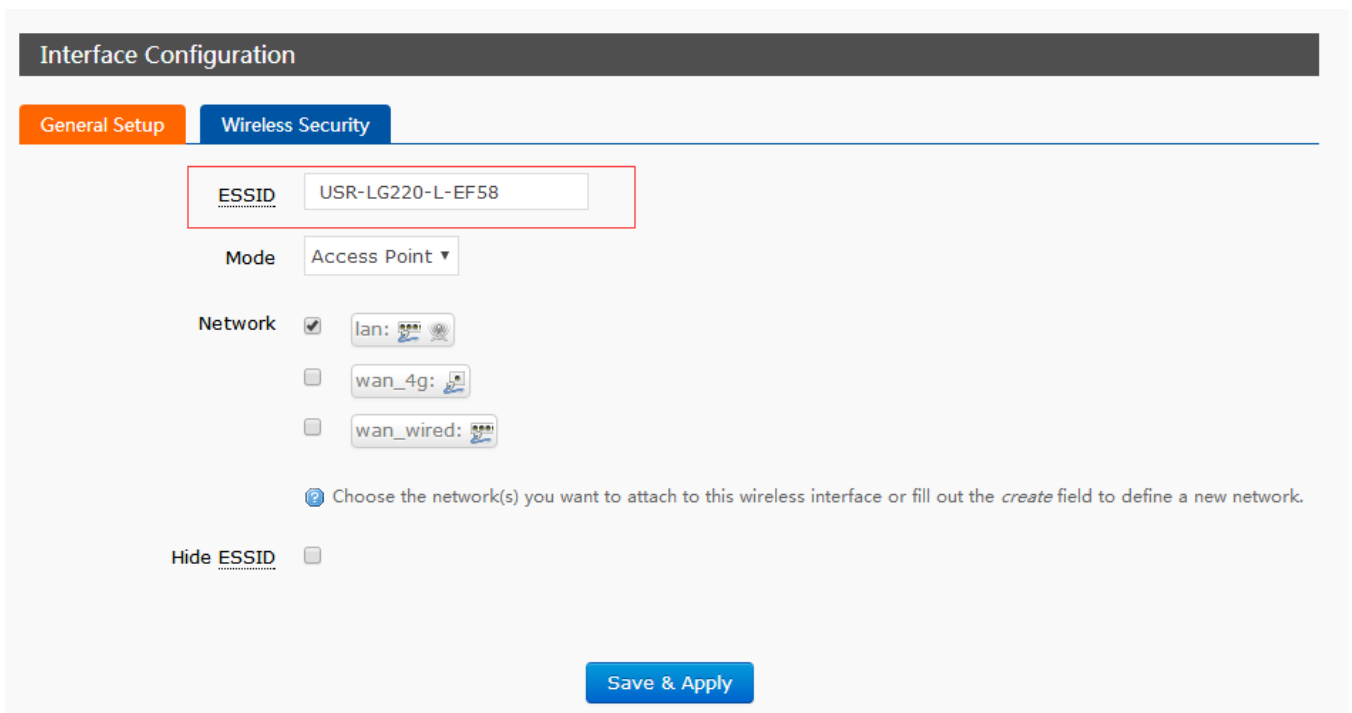
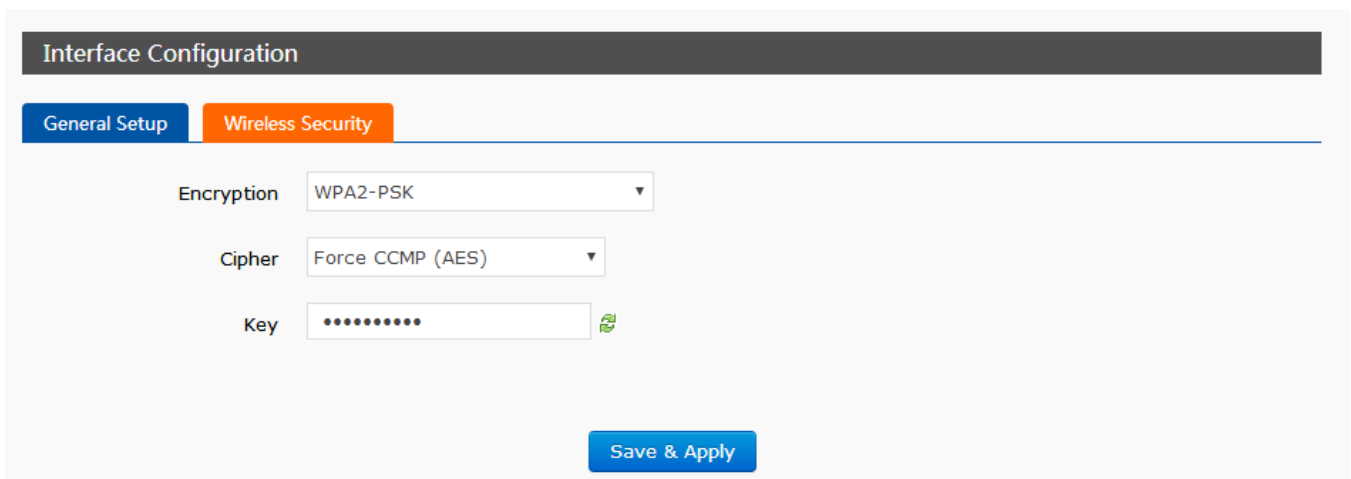

Figure 25 Configure SSID

User can configure password on Web Server as follow:



Interface Configuration

General Setup | **Wireless Security**

Encryption: WPA2-PSK

Cipher: Force CCMP (AES)

Key: ••••••••

Save & Apply

Figure 26 Configure password

Other settings on Web Server as follow:

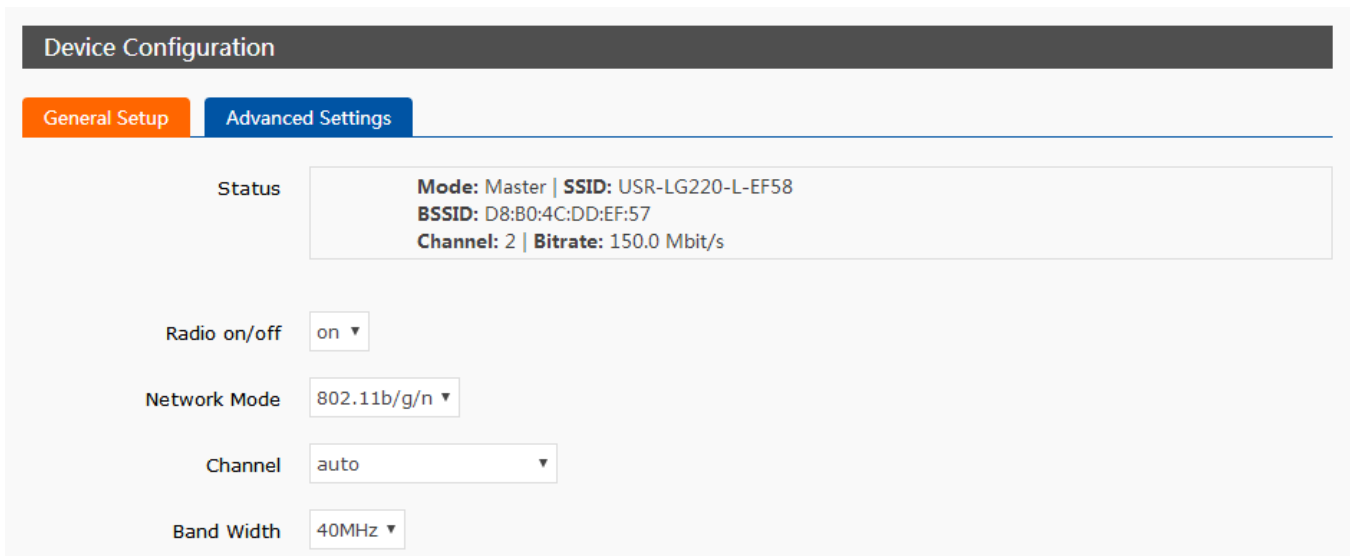

Device Configuration

General Setup | **Advanced Settings**

Status: **Mode:** Master | **SSID:** USR-LG220-L-EF58
BSSID: D8:B0:4C:DD:EF:57
Channel: 2 | **Bitrate:** 150.0 Mbit/s

Radio on/off: on

Network Mode: 802.11b/g/n

Channel: auto

Band Width: 40MHz

Figure 27 WiFi interface Other settings

User can close WiFi interface by changing 'Radio on/off' into off.

2.5.4. Network Diagnosis

User can use network diagnosis function by Web Server as follow:

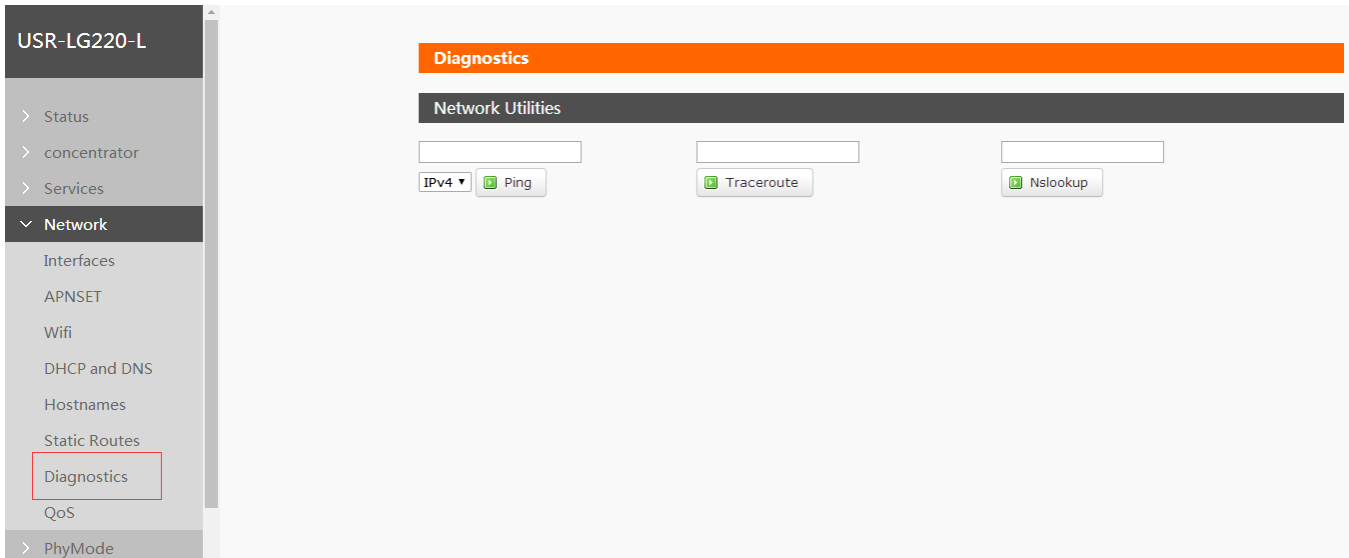

Figure 28 Network diagnosis

- Ping: User can do PING test to a specific address in LG220.
- Traceroute: Can acquire routing path to visit a specific address.
- Nslookup: Can analyse DNS into IP address

2.5.5.Upgrade firmware

Upgrade by Web Server as follow:

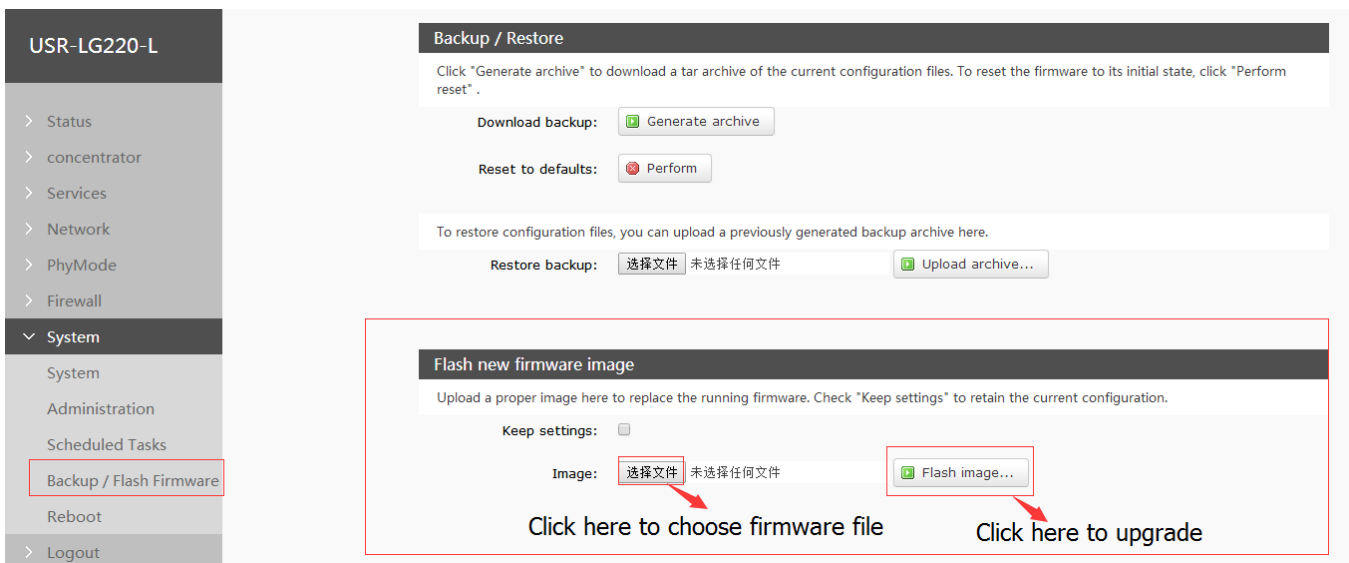

Figure 29 upgrade firmware version

Note:

- The whole upgrade process will last for some time and user can try to enter Web Server again after waiting some time.
- User can choose saving settings.
- User should keep powering up and LAN/WiFi connection during the whole upgrade process.

2.5.6.Restart

Restarting time is about 60 seconds.

Restart by Web Server as follow:

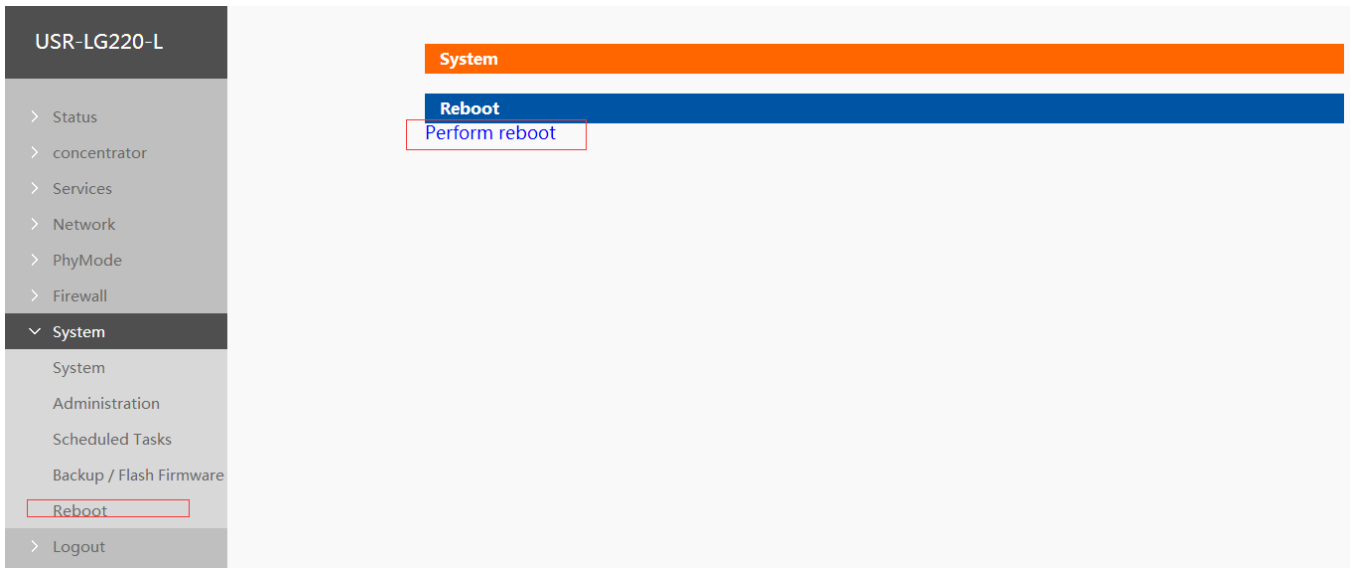

Figure 30 Restart module

3.Configuration

3.1.Configuration procedure

Procedure:

Power off LG220->Insert SIM card and connect cable to WAN interface->Connect WiFi antenna, LoRa antenna and 4G antenna->Power LG220->Wait about one minute and observe LED status(WAN LED and 2G/3G LED start lighting means LG220 can access internet)->Enter Web Server, configure LG220 and restart LG220

Note: After inserting SIM card, user needs to configure APN settings to make LG220 connect to 4G network firstly.

3.1.1.Web Server

When user needs to configure the LG220 , user can connect PC to USR-LG220 through WiFi interface, then enter LG220 Web Server.

Default parameters of LG220 as follows:

SSID	USR-LG220 -L-XXXX
IP Address	192.168.1.1
User name	root
Password	root
WiFi Password	www.usr.cn

Figure 31 LG220 default parameters

Take default parameters as example: User can connect PC to SSID USR-LG220 -L-XXXX. Then open browser and enter 192.168.1.1, log in with User name and Password(both are root), user can enter Web Server.

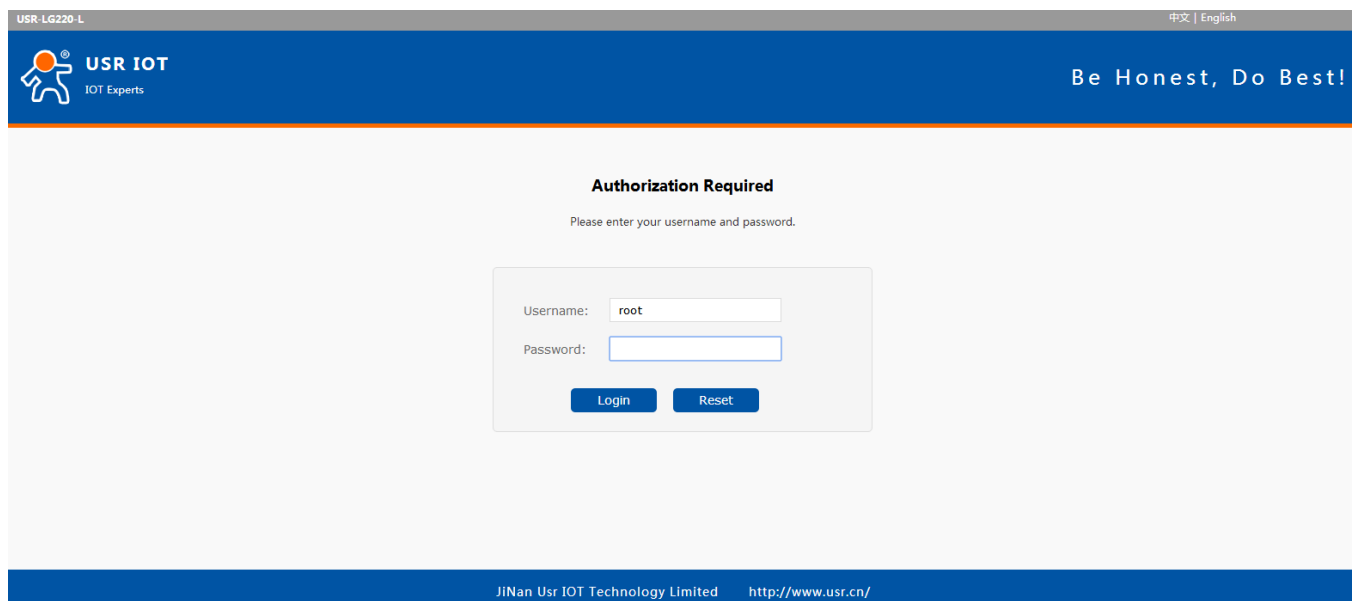

Figure 32 Web Server login web

User can change the language between Chinese/English in the top right corner.

4.Contact Us

Company: Jinan USR IOT Technology Limited

Address: Floor 11, Building 1, No. 1166 Xinluo Street, Gaoxin District, Jinan, Shandong, 250101, China

Web: www.usriot.com

Support: h.usriot.com

Email: sales@usr.cn

Tel: 86-531-88826739/86-531-55507297

5.Disclaimer

This document provides the information of USR-LG220 products, it hasn't been granted any intellectual property license by forbidding speak or other ways either explicitly or implicitly. Except the duty declared in sales terms and conditions, we don't take any other responsibilities. We don't warrant the products sales and use explicitly or implicitly, including particular purpose merchant-ability and marketability, the tort liability of any other patent right, copyright, intellectual property right. We may modify specification and description at any time without prior notice.

6.Update History

2018-03-05 V1.0.6.01 established based on Chinese version V1.0.6.