

## USR-K1 Super Port

File version: V1.0.4

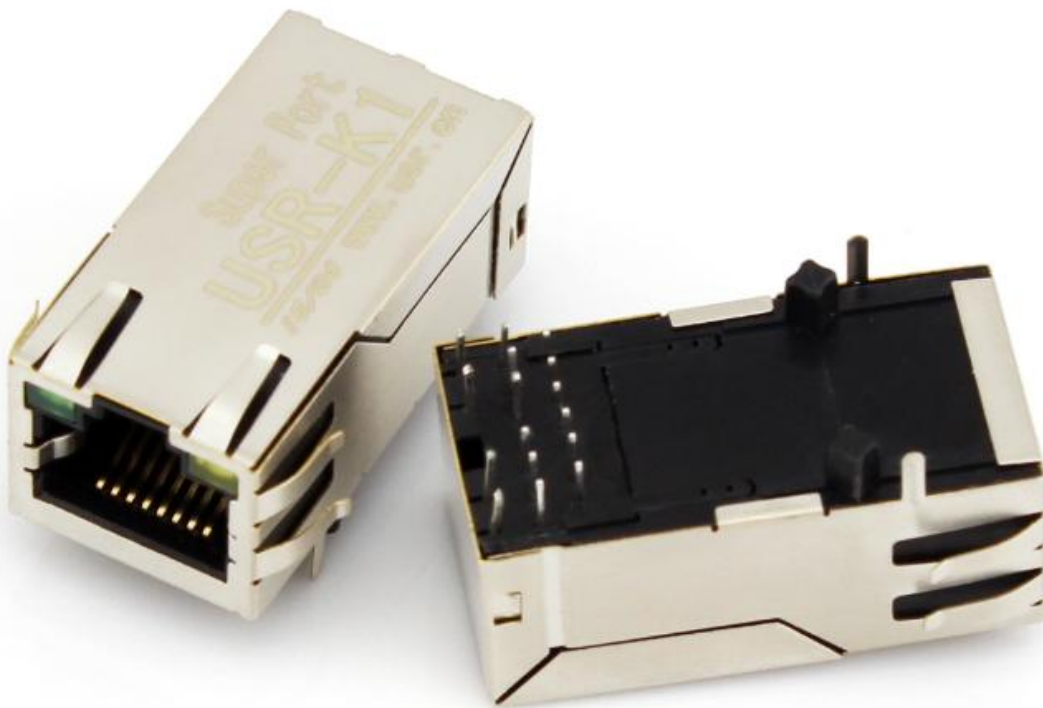

USR-K1 is the high performance-cost version of Super Port .It is an embedded serial networking module, whose function is to realize bidirectional transparent transmission between UART TTL and Ethernet .The amazing part of K1 lies in its Ethernet port integration design .You can apply K1 to your products to realize networking communication .User can directly process data interaction through network and device to realize remote data acquisition, remote control and management.

K1 is based on the design concept of "Simple,Reliable,Affordable" .And it has the same kernel solution and parameters as USR-TCP232-T.

## Content

USR-K1 Super Port .....	1
1. Product Introduction.....	3
1.1 Brief Intro .....	3
1.2 Function Features .....	3
1.3 Product Characteristics .....	3
1.4 Order Symbol .....	4
1.5 Electrical Characteristics .....	4
2. Default Parameter Test .....	5
2.1 Hardware Connection.....	5
2.2 Set-up Software .....	5
2.3 Communication Test.....	7
2.4 Parameter Setting.....	7
2.4.1 Set via Net .....	7
2.4.2 Set via COM. ....	8
2.4.3 Set DIY .....	9
3. Module Work Mode.....	10
3.1 Structure Chart .....	10
3.2 UDP Mode .....	10
3.3 TCP Client.....	11
3.4 UDP Server Mode.....	11
3.5 TCP Server Mode .....	12
3.6 Virtual COM Mode .....	13
4. Hardware Description .....	15
4.1 Technical Specifications.....	15
4.2 Hardware Description.....	16
4.3 Hardware to RJ45 Light.....	18
4.4 Size.....	18
5. Expand Functions .....	19
5.1 RS485 .....	19
5.2 Link .....	20
5.3 Reset.....	20
5.4 ID .....	20
5.5 Index .....	22
5.6 RFC2217 .....	23
6. Common Questions .....	26
6.1 Work Across Network Segment .....	26
6.2 More Network Cards .....	26
6.3 Every Period of Time, Module Dropped.....	26
6.4 Search Device Failure, Port Occupied .....	27
7. Revision history.....	28
8. Contact Us.....	29

# 1. Product Introduction

## 1.1 Brief Intro

USR-K1 is the high performance-cost version of Super Port. It is an embedded serial networking module, whose function is to realize bidirectional transparent transmission between TTL and Ethernet. The amazing part of K1 lies in its Ethernet port integration design. You can apply K1 to your products to realize networking communication. User can directly process data interaction through network and device to realize remote data acquisition, remote control and management.

K1 is based on the design concept of "Simple,Reliable, Affordable". And it has the same kernel solution and parameters as USR-TCP232-T.

## 1.2 Function Features

- 10/100M auto detect interface;
- Support AUTO MDI/MDIX, Can use a crossover cable or parallel cable connection;
- Serial com port bound rate can set up from 300 to 961200,and None,Odd,Even,Mark,Space five check bits;
- Work mode TCP Server, TCP Client, UDP, UDP Server;
- Working model related parameters can be set via a serial port or network;
- 3.3 V TTL level compatible;
- Small Size
- Virtual serial port supported;
- Unique heartbeat package mechanism to ensure that the connection is reliable, put an end to connect feign death;
- Under UDP mode, Packet Broadcast is prohibited, with stronger anti-interference ability;
- Across the gateway, across switches, routers;
- Can work in LAN, also can work on the Internet (external network);

## 1.3 Product Characteristics

- 32 bits ARM CPU inside;
- LAN : 10/100Mbps; protect: Built-2KV isolated electromagnetic;
- Serial port baud rate: from 2400 to 961.2 KBPS can be set up;
- Network protocol: ETHERNET ARP IP UDP TCP ICMP;
- Software tool: configuration software, TCP/UDP test soft, RS232 debug soft;
- Configuration method: serial com port or via Ethernet, free software available;
- Operating temperature: -25~75°C;

- Storage environment: -40~85°C, 5~95%RH.
- Compact type

## 1.4 Order Symbol

name	symbol	Description Remarks
Super Port	USR-K1	

Diagram 0-1 order symbol

## 1.5 Electrical Characteristics

Model number	Power supply DC	current
USR-K1	3.3V	185mA(165-195)

Diagram 0-2 Electrical Characteristics

## 2. Default Parameter Test

Pls connect the product with your computer or router to test its performance.

FAQ: <http://www.usriot.com/Search/getList/keyword/t24/>

### 2.1 Hardware Connection

1.You can using "USR-TCP232-EVB". It's easier to test. USR-TCP232-EVB is power for DC 5V@200mA.



Diagram 2-1 USR-K1 Connection diagram

3.If you don't have "USR-TCP232-EVB",please refer to 5.4

### 2.2 Set-up Software

Set-up Software with link <http://www.usriot.com/Download/237.html> as  can help to view default setting then set the parameter.

1. Search in LAN (Firstly, ensure the computer IP is static. The module IP is 192.168.0.201by default; Disable firewall, antivirus soft and WIFI).

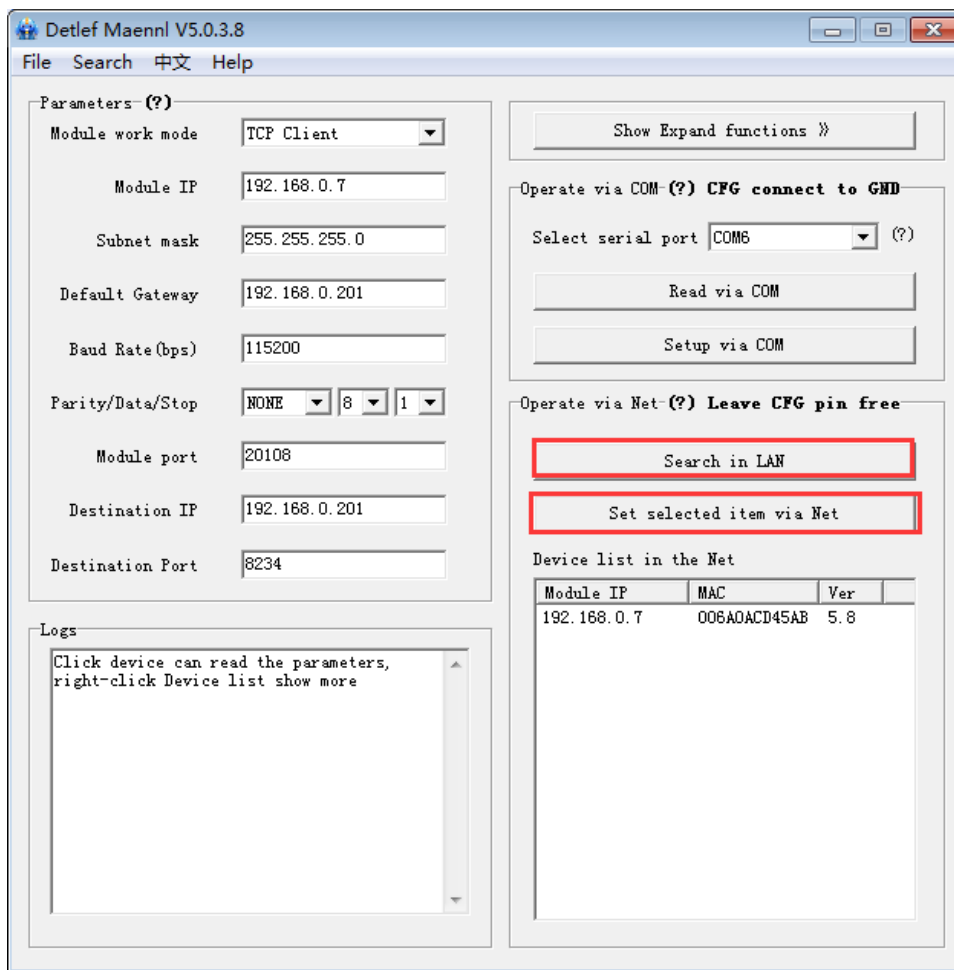

Diagram 2-2 the default parameters

2. Keep default parameter set up your pc.

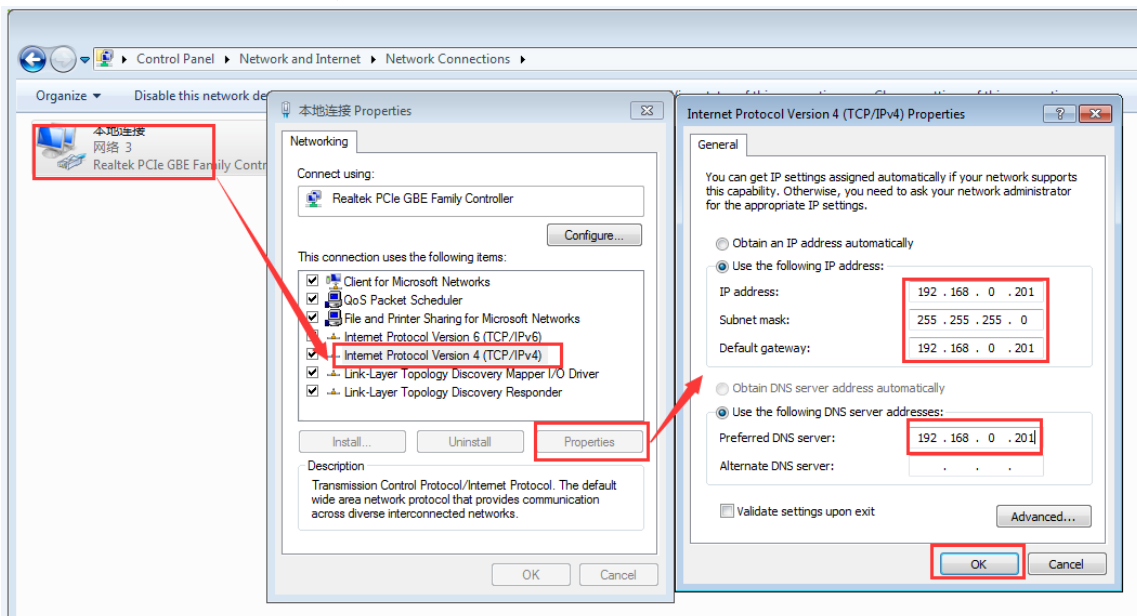

Diagram 2-3 pc parameter

## 2.3 Communication Test

 **USR-TCP232-Test** (link <http://www.usriot.com/Download/199.html>) can help you test.

Serial to net debugging tester application:

1. Ensure the COM port baud rate, check bits, data bits, stop bit correspond to module parameters.
2. Ensure network protocol, IP address, port number correspond to module parameters.
3. Open COM and the web then connect. They begin transparent transmission after choose the module IP.

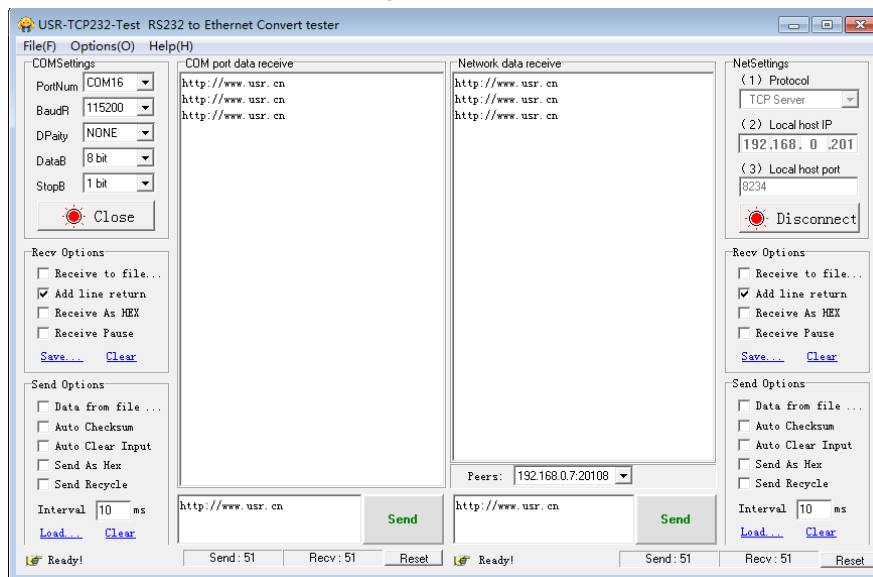

Diagram 2-4 USR-TCP232-Test Parameter

## 2.4 Parameter Setting

### 2.4.1 Set via Net

1. Hardware Connection, refer to [2.1 Hardware Connection](#)
2. Search module,
3. Click "Search in LAN"
4. Setting your Parameter
5. Click "Set selected item via Net"
6. Waiting for ten seconds and Click "Search in LAN" check it.

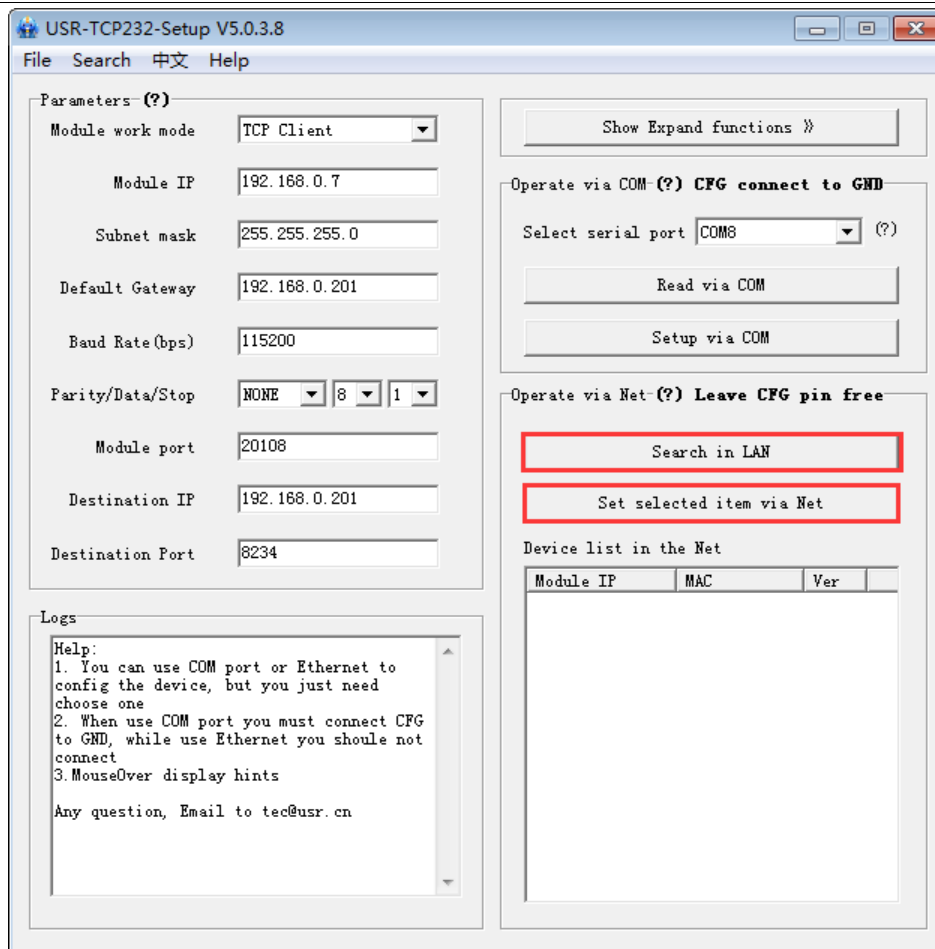

Diagram 2-5 Set via net

## 2.4.2 Set via COM.

1. Hardware Connection, refer to [2.1 Hardware Connection](#)
2. Connect CFG to GND pin
3. Click "Read via COM"
4. Setting your Parameter
5. Click "Read via COM" and check it
6. Switch off CFG.



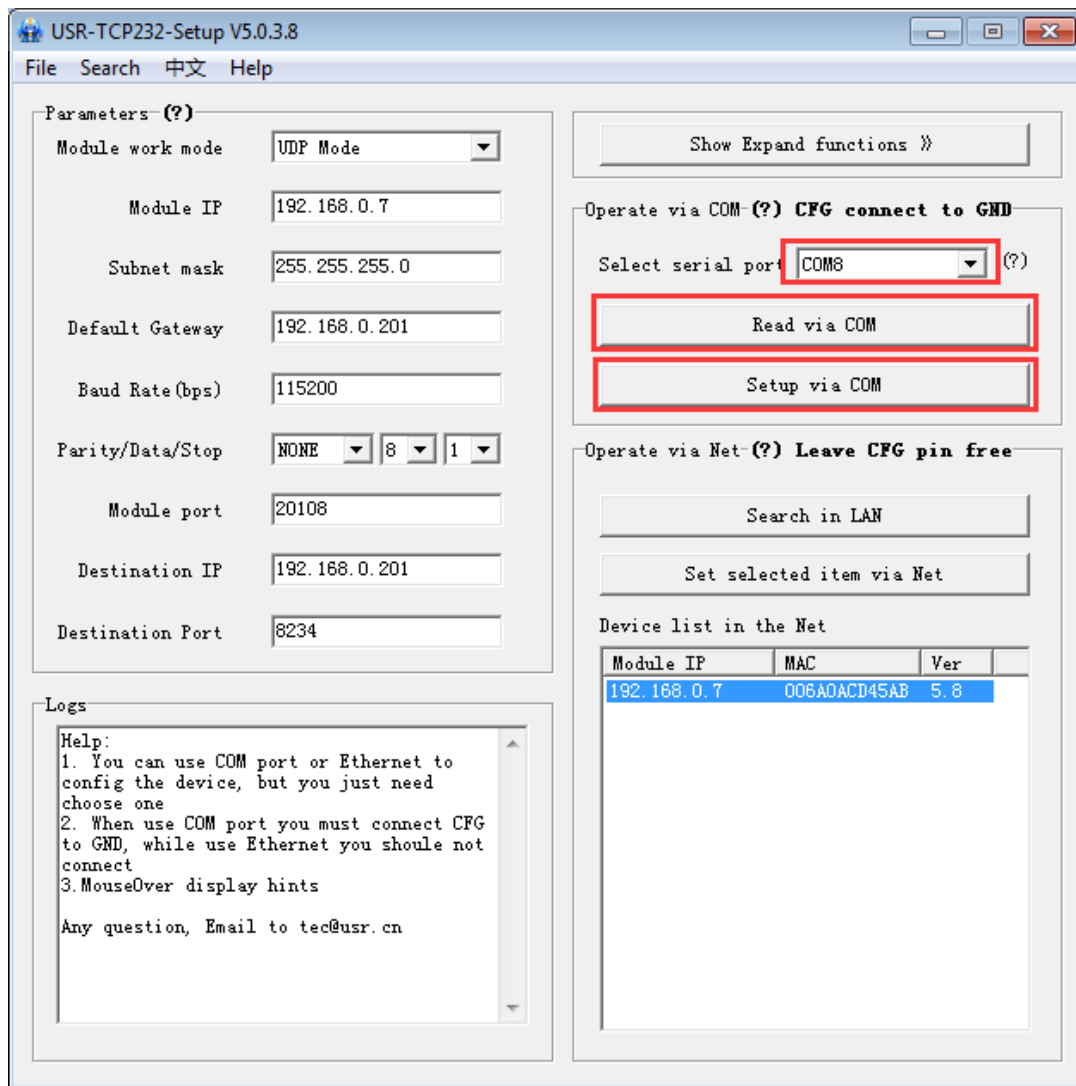

Diagram 2-6 Set via COM

### 2.4.3 Set DIY

By setting protocol, load in <http://www.usriot.com/Download/206.html>

### 3. Module Work Mode

#### 3.1 Structure Chart



Diagram 3-1 structure chart

#### 3.2 UDP Mode

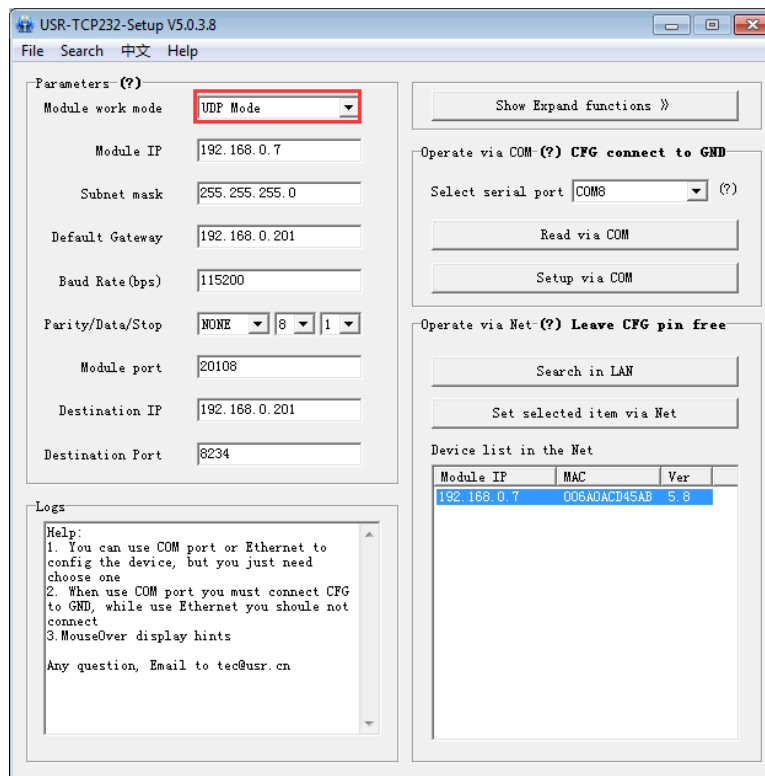

Diagram 3-2 UDP Mode

In UDP mode, after the module is powered on listening on port Settings, not take the initiative to establish a connection, when data from by forwarding to the serial port, when a serial port receives the data sent over the network to the IP and port module Settings.

### 3.3 TCP Client

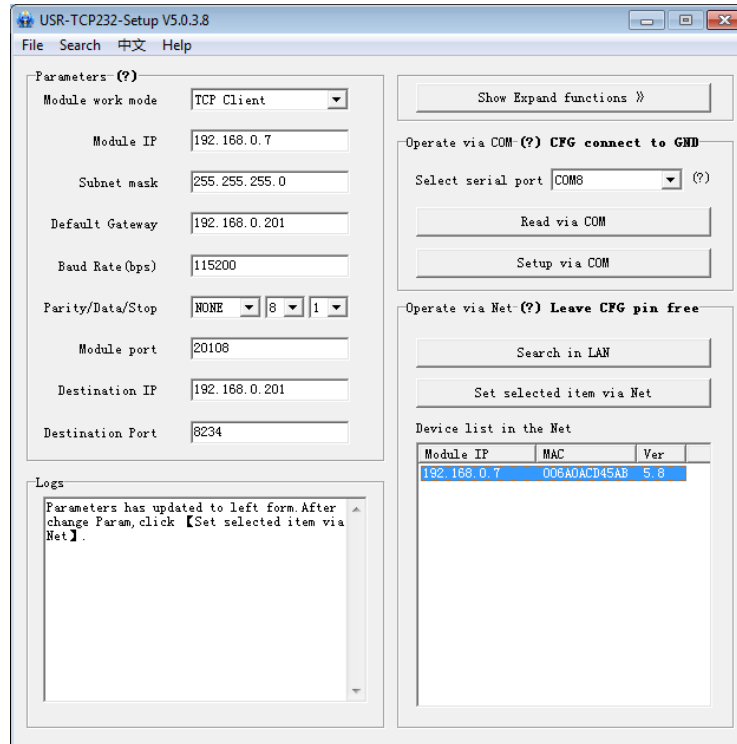

Diagram 3-3 TCP Client

In TCP client mode, after power on module according to their own Settings active TCP server to connect to the server, and then establish a long connection, data transparent transmission on this mode.

### 3.4 UDP Server Mode

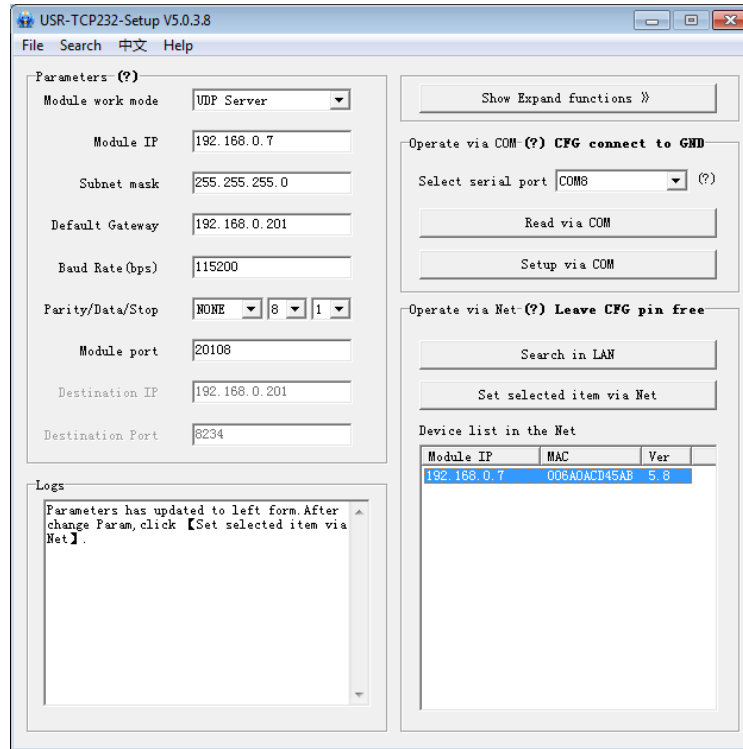

Diagram 3-4 UDP Server Mode

UDP server refers to the normal UDP are not validated on the basis of the source IP address, destination IP instead of the UDP packets are received data source IP, similar to TCP server functionality.

In this mode, the module by default record a destination IP and destination port, when a serial port data, to record the IP to send data, at the same time, the module at the server status, to accept the network packets sent to module, and adjust the target IP IP for the data source, suitable for multiple IP working mode for the module.

Use computer end program and UDP mode is exactly the same, no need to change.

**Note:**UDP mode, UDP server mode with a single maximum length of 1472 bytes should be controlled at or below.

### 3.5 TCP Server Mode

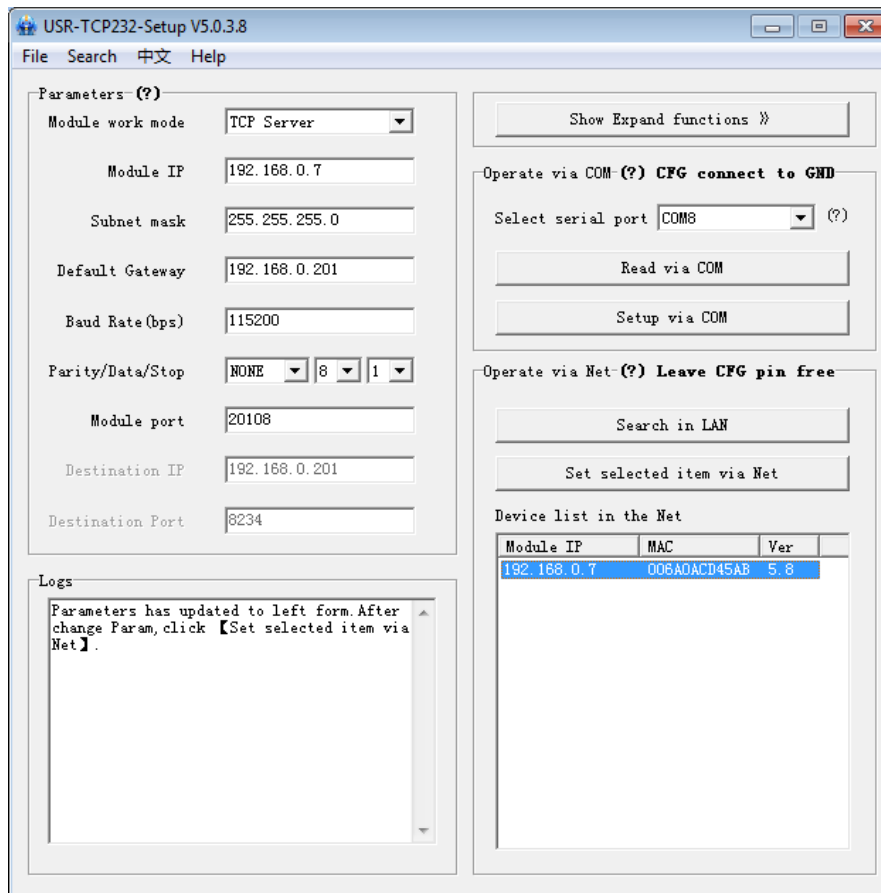

Diagram 3-5 TCP Server Mode

In TCP Server mode, module and gateway trying to communication first, and then monitor set up local port, there is connection request response and create a connection, can exist at the same time up to 4 links, a serial port after receipt of the data will be sent to all at the same time of establishing links with network module device.

USR-TCP232-SETUP software, set the Index function can be achieved when to establish a multi-channel connection, the module can identify communications equipment, and with the specified device to communicate.

### 3.6 Virtual COM Mode

Virtual COM means to convert data TCP connected to data of a COM within PC for transparent transmission. Take TCP Client mode for example:

Loading <http://www.usriot.com/Download/31.html>

1. Disable firewall and antivirus program
2. Install Virtual COM

### 3. Setting TCP Server

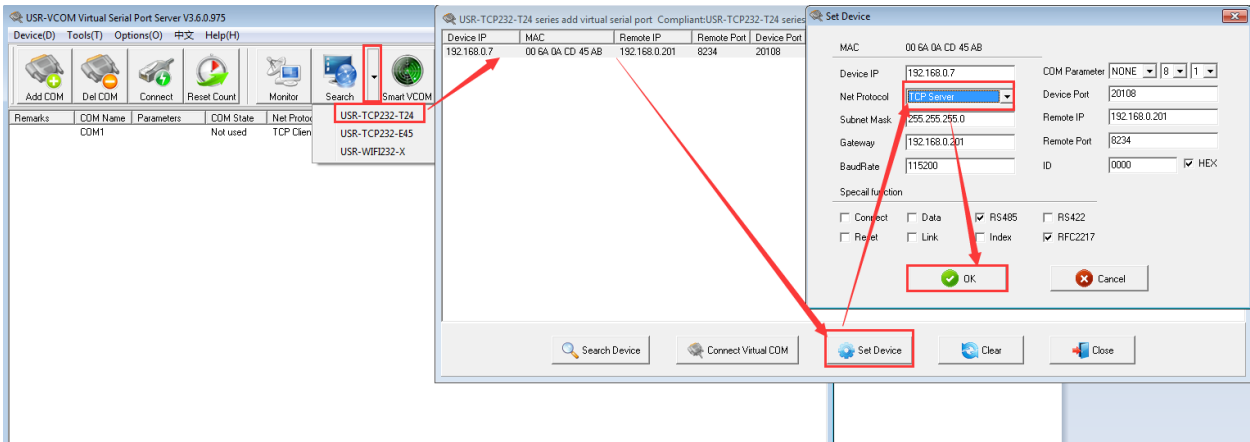

Diagram 3-6 Virtual COM

### 4. Connect a com

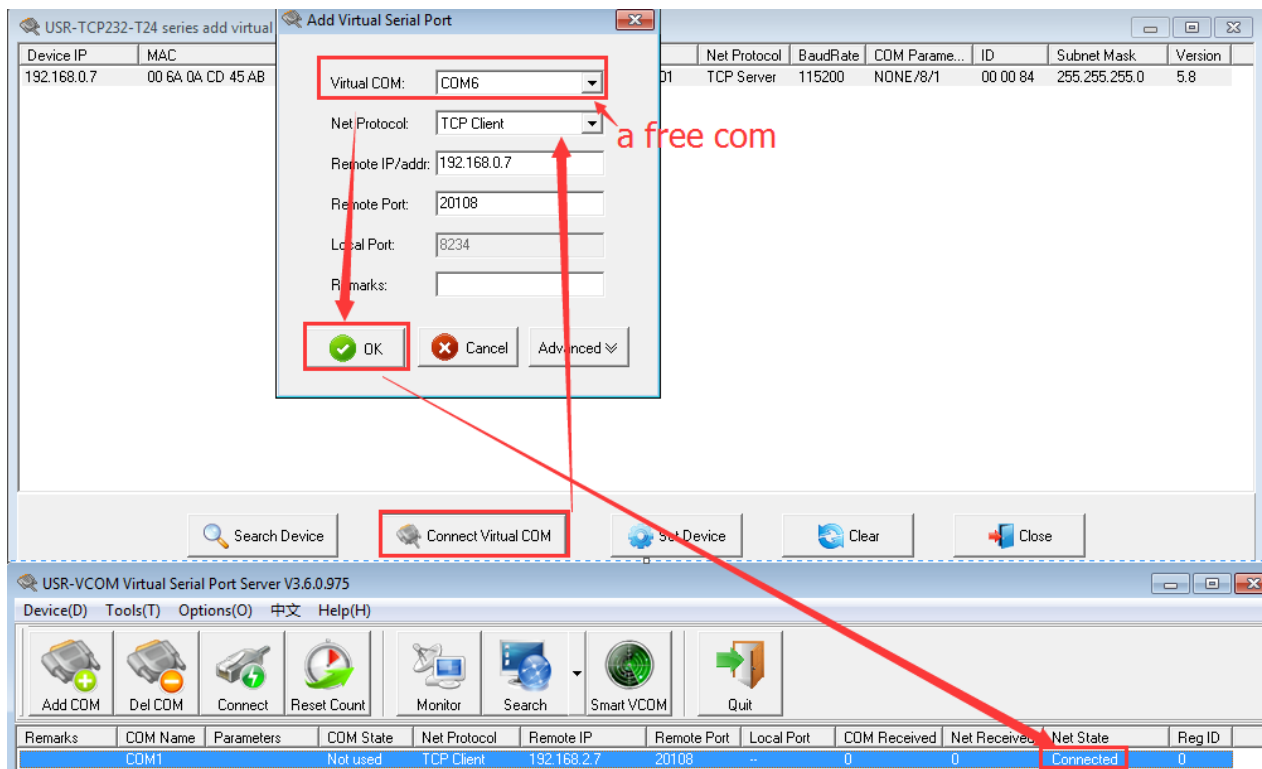

Diagram 3-7 Virtual COM

## 4. Hardware Description

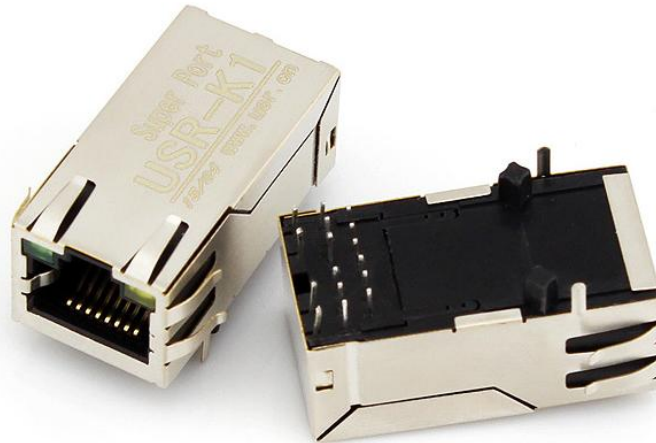

Diagram 4-1 USR-K1

PCB lib: <http://www.usriot.com/Download/232.html>

### 4.1 Technical Specifications

Major characteristic	Parameter
Name	USR-K1
CPU	32bit 48MHz (Cortex-M0)
Flash	32KBit
RJ45	
Socket	1
Speed	10/100M MDI/MDIX
Net protocol	IP, TCP, UDP, ARP, ICMP
Buffer	send: 2K bytes, receive: 1K bytes
Network interface	8 pin RJ45
Serial	
Port Number	1
Interface Standard	TTL: pin type 3.3V
Data Bits	5, 6, 7, 8
Stop Bit	1, 1.5, 2
Check Bit	None, Even, Odd, Space, Mark

Baud Rate	300 bps ~790 Kbps
Flow Control	null
Buffer	receive: 800 bytes
RS-485 Pull-up and Pull-Down Resistor	null,reserved 485 send-receive control pin
Parameter specification	
Physical Size:	PCB size: 21.6*13.5*32.6MM (L*H*W)
Temperature and humidity range	Operating temperature: -25 to 75 ° C Storage temperature: -40 to 80 ° C Storage humidity: 5% to 95% RH

**Diagram 4-2 Technical Specifications**

## 4.2 Hardware Description

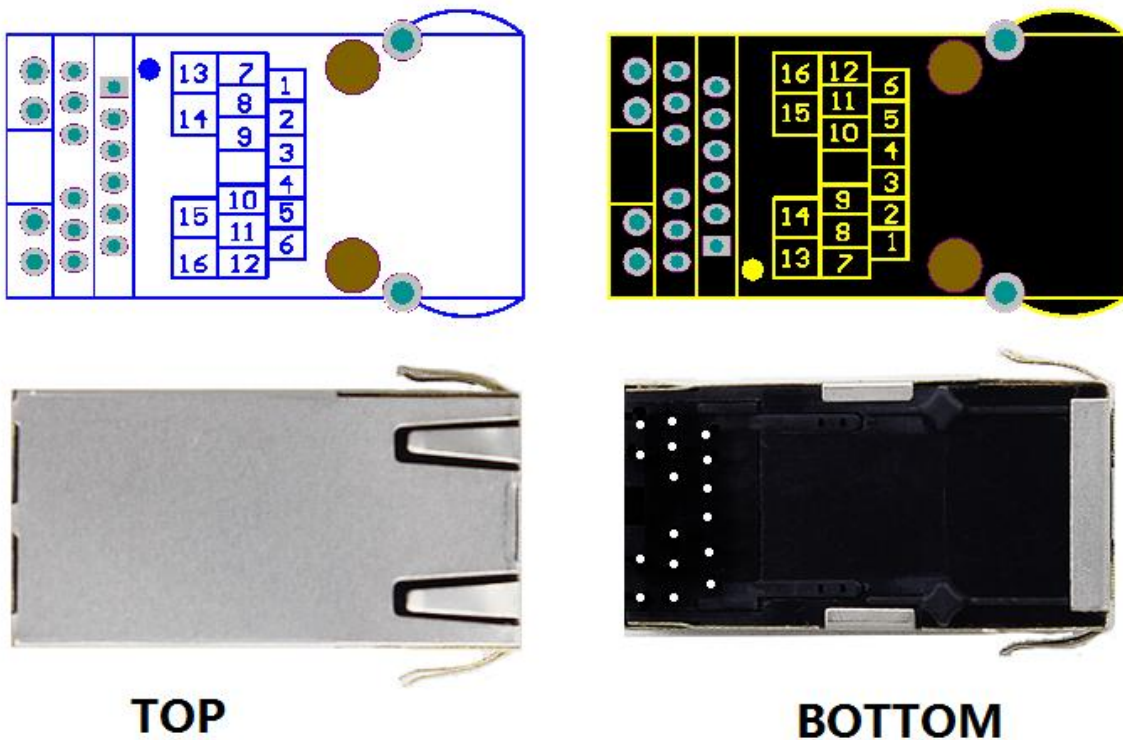
**Diagram 4-3 Technical Specifications**



No.	Pin	Function	Descriptions
1	ISP	Update pin	This pin to ground to the module power module can be upgraded.If you do not use, can be suspended.
2	N/C	N/C	N/C
3	LINK		Can be used as a network connection status indicator pin
4	RST	RESET	Pin received 200ms low to reset the whole module. If you do not use, can be suspended. Note: The module is powered automatic reset, it is recommended that connect the MCU IO port, reset the MCU control module in a particular case.
5	485_EN	485 enable	Can be used as RS485 enable pin
6	CFG	Serial ports Configuration pins	Low, you can use the serial port module configuration. Normal working hours left floating or tied HIGH. Note: give the power module, and then pulled down the CFG pin to enter the serial configuration state.
7	LED2	Network data instructions	Connect to 13
8	RXD	Module data is received	Data receiving end of the module, TTL 3.3V microcontroller
9	TXD	Module data transmission	Data transmission end of the module, TTL level can be connected to 5V or 3.3V microcontroller
10	GND	Signal ground	GND
11	VCC	Power supply	Power supply: 3.3V @ 200mA
12	LED1	Network connection status indicator	Connect to 16
13	LED2	Network data instructions	Connect to 7
14	LED_3. 3	Network led power	Power 3.3V
15	LED_3. 3	Network led power	Power 3.3V
16	LED1	Network connection status indicator	Connect to 12

Diagram 4-3 I/O introduce

### 4.3 Hardware to RJ45 Light

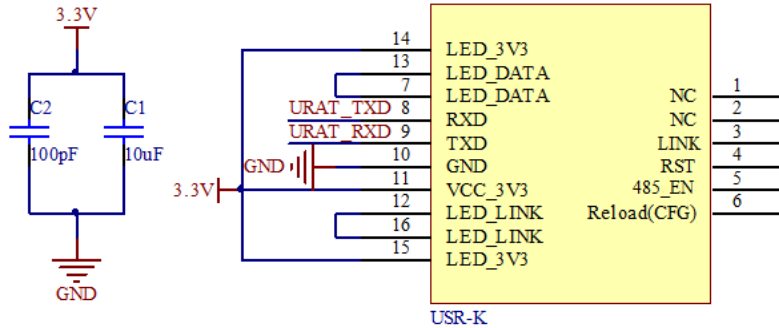
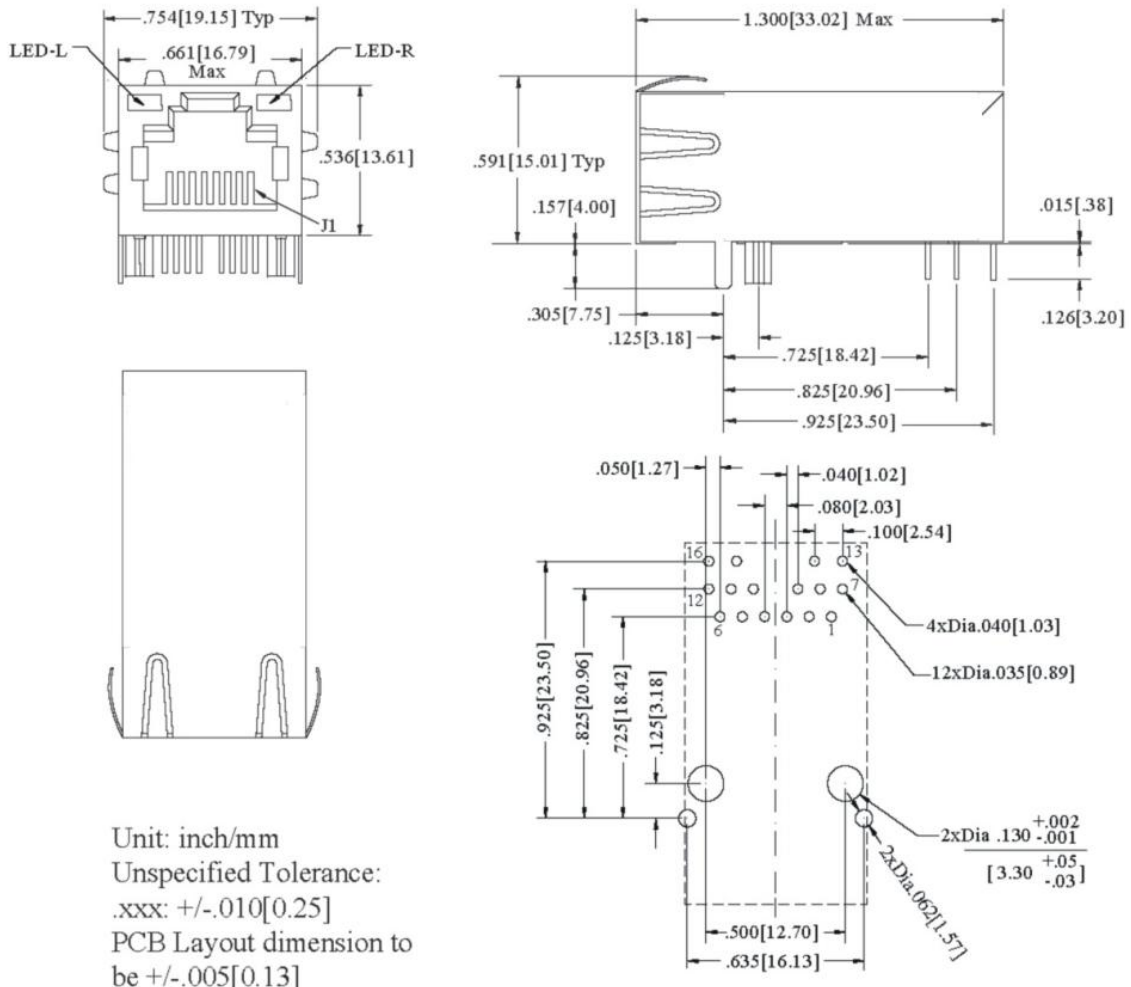

Diagram 4-4 Hardware to RJ45 light

### 4.4 Size



Recommended PCB Layout Component Side View

Diagram 4-5 size

## 5. Expand Functions

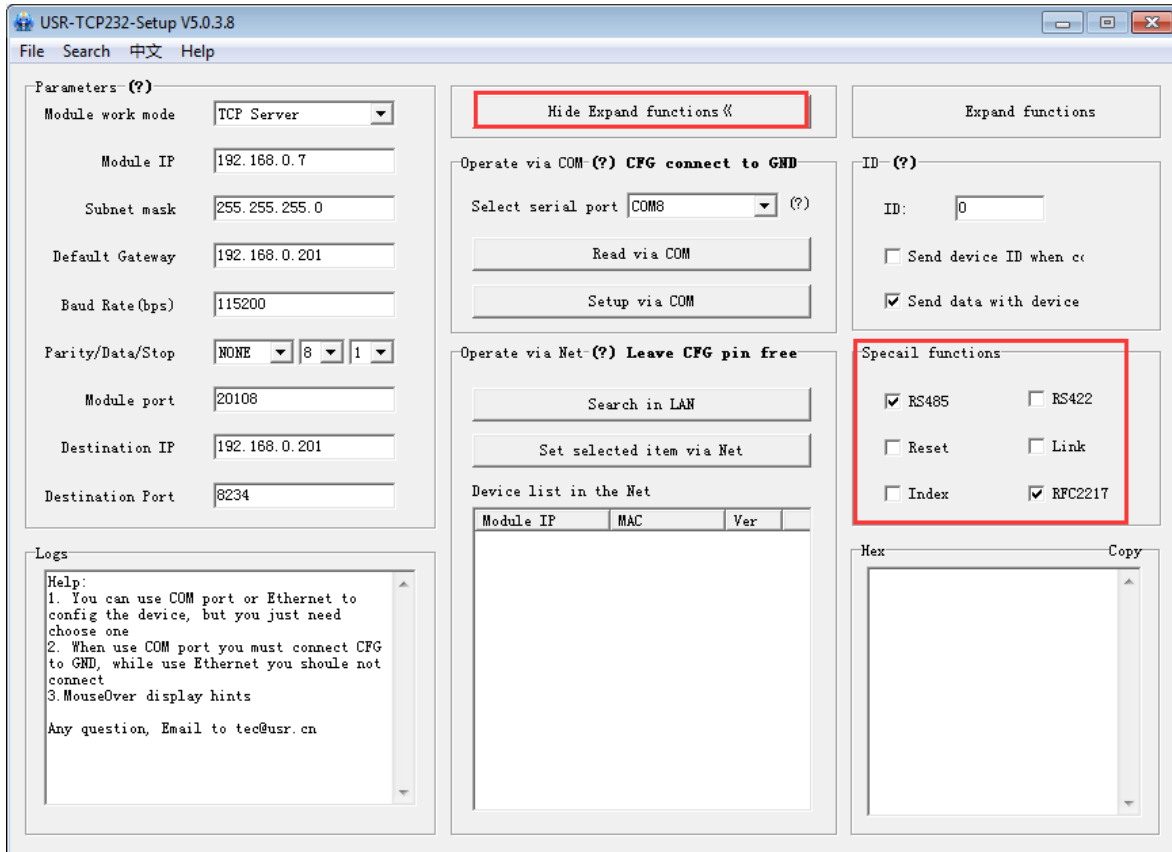

Diagram5-1 Expand functions

### 5.1 RS485

“485\_en” for RS485, external enable control pin.

Set the software interface:

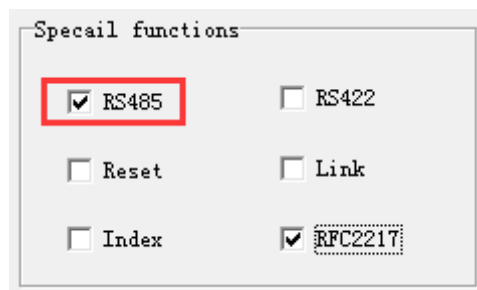

Diagram5-2 RS485

Select it by default

## 5.2 Link

The Link pins for the module to establish a communication connection status indicates pin, establish the communication Link pin will output low level, no connection is established, output high level.

"Link" for external Link instructions .

Set the software interface:

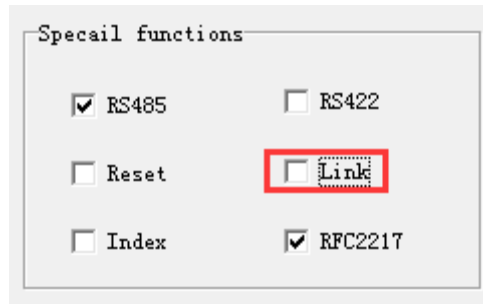

Diagram5-3 Link

Don't select it by default

## 5.3 Reset

When the module as a TCP Client-side, the module will take the initiative to connect TCP SERVER. When the Reset function, the module tries to connect to TCP Server-side 30 times, still unable to establish a connection, the module will automatically restart.

Set the software interface:

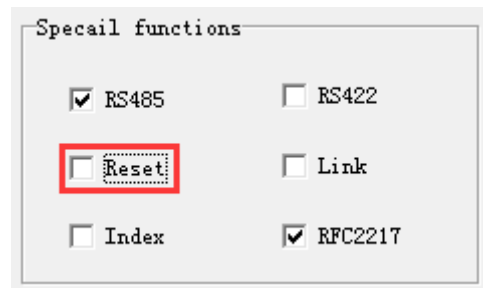

Diagram5-3 Link

Don't select it by default

## 5.4 ID

Module as TCP Client-side ID function for TCP Server-side distinguish between data sources, to achieve the establishment of the connection or data communication process device ID will also be sent, the module ID number is set to decimal, range 0 - 65535, requires the receiving end HEX format.

1.Select "Connect" to establish a communication connection, TCP Server-side will receive the corresponding TCP Client-side ID (ID Description: The first four shows for the ID number, the last four digits of the display ID negated to authentication).

The following picture shows the module do TCP CLIENT establish a communication connection ID feature is enabled, the setup interface module ID number 12

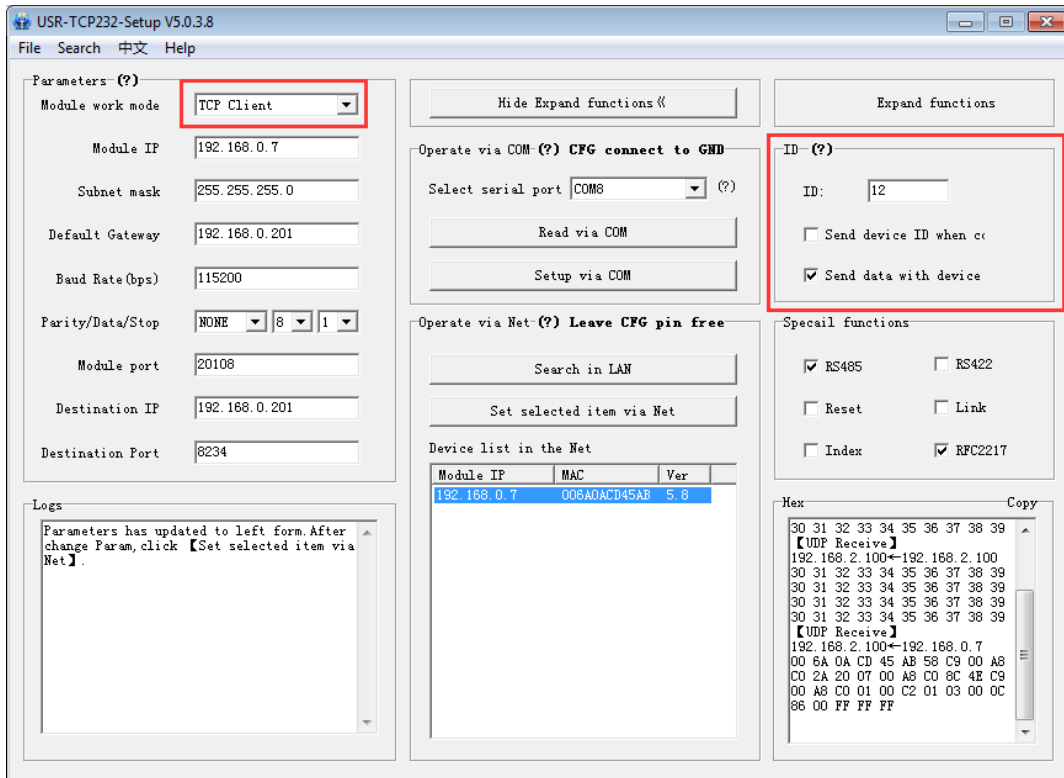

Diagram5-4 ID

Don't select it by default

The figure below shows establish a communication connection ID function, the device through the serial communication interface to the TCP Server-side:

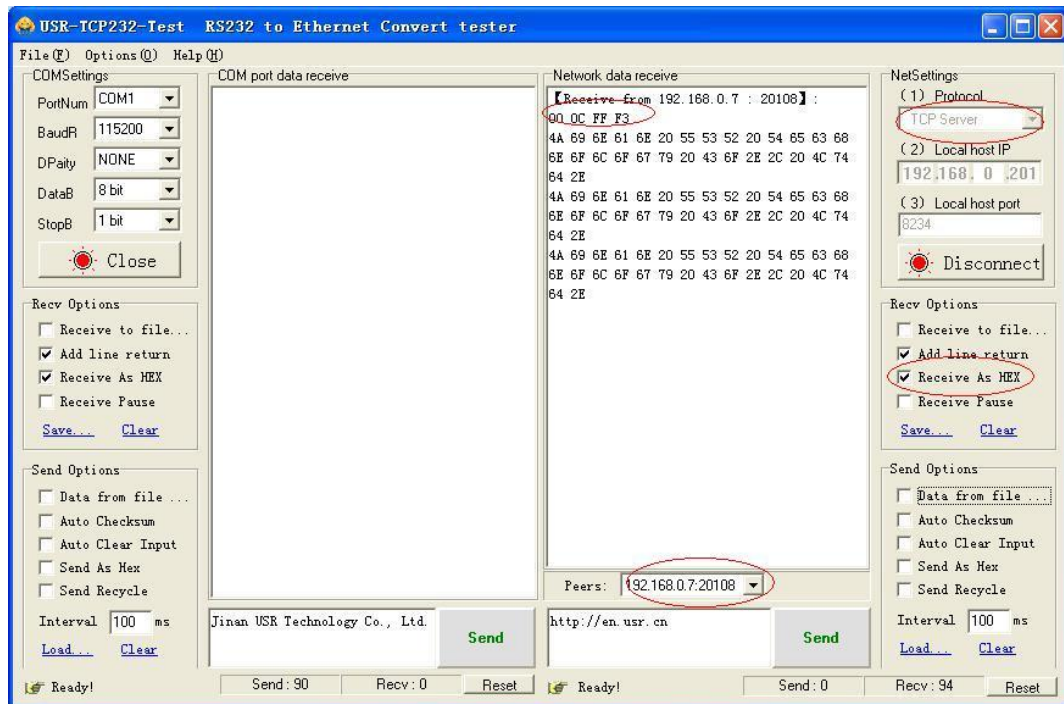

Diagram5-5 USR-TCP232-Test ID

2. Select data during each data transfer, TCP Server-side will receive the corresponding TCP Client-side ID (ID Description: ID before data transmitted only display four-digit ID number).

The following picture shows the module do the TCP CLINENT ID feature is enabled, data transmission module ID number 12 setting interface:

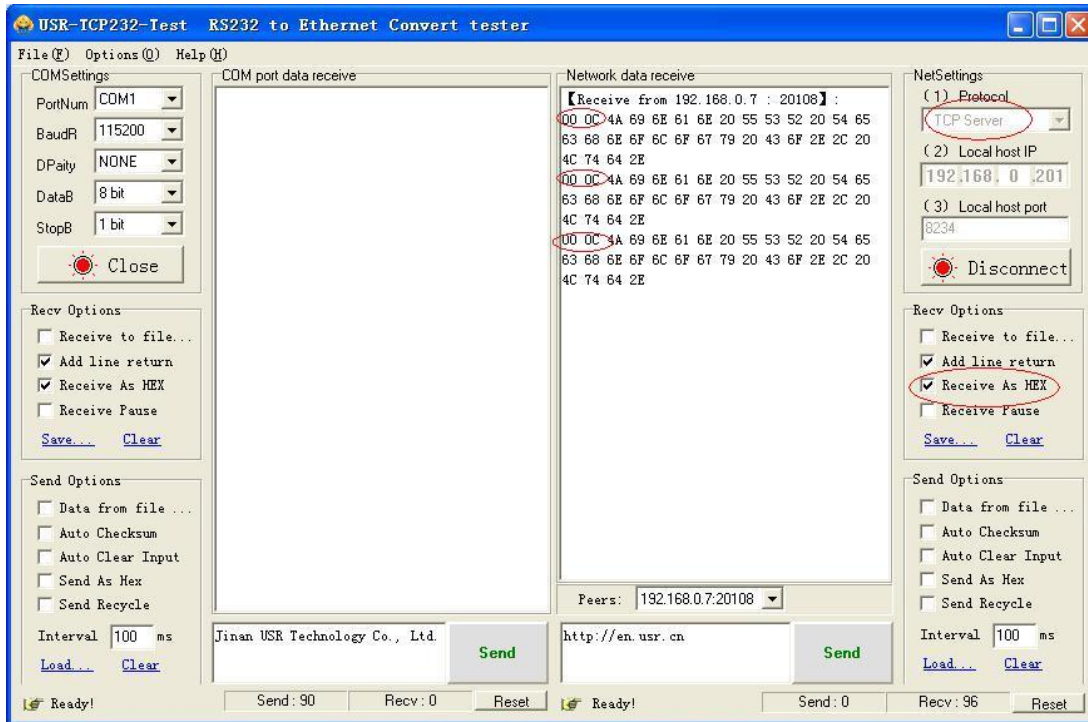

Diagram5-6 USR-TCP232-Test ID

The figure below shows the data communication ID function, the device through the serial port to TCP Server communication interface:

## 5.5 Index

Module as TCP SERVER end up at the same time to establish four connections, server-side at the same time send data to four CLIENT and SERVER the receiving Client-side data can not distinguish between sources of data, the Index function can send and receive data source selection.

Index function is enabled, communication data is displayed corresponding Client side device number, specific parameters are described below:

1. When receive data from Ethernet, module will send data to serial port with head 49 N , followed by data. 49 represent incoming data, N represent client index.
2. When user MCU want send data to module serial port, start with head 4F N data... 4F represent send out, N represent which client.
3. When new TCP connection incoming, module will send 43 N M to serial port, indicating that there is current link N accessed, total link number M.
4. When link number have exceed maximum, new link requirement will lead to message 46 46.
5. When disconnect, module will send 44 N M, represent current link N is delete, left link M.

**Note:** The above values set are HEX format.

Set the software interface:

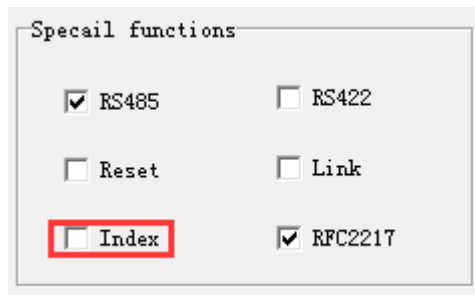

**Diagram5-7 Index**

Don't select it by default

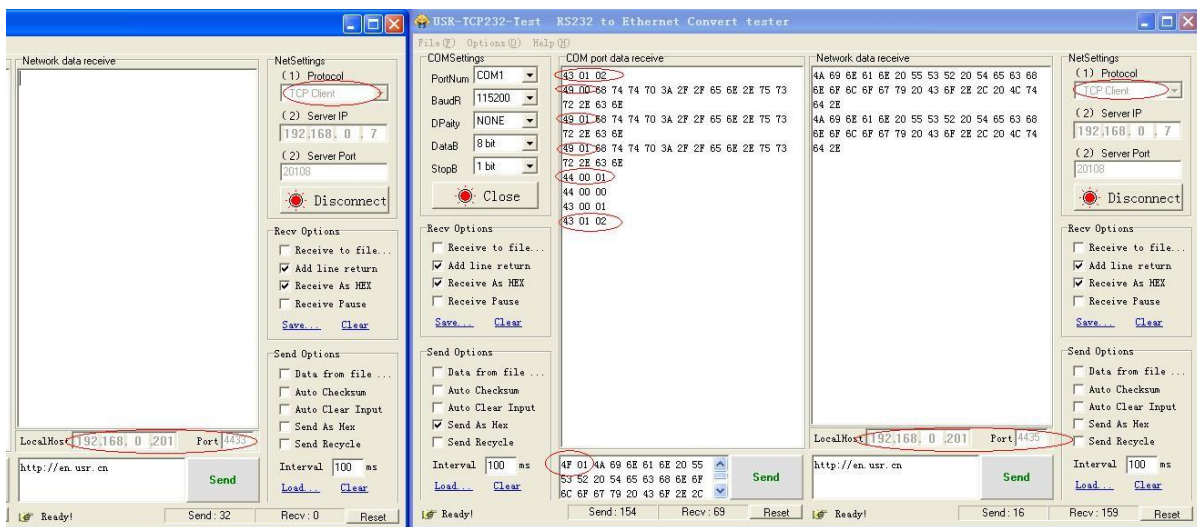

**Diagram5-7 the test of index**

## 5.6 RFC2217

RFC2217 is an agreement for setup com port settings via Ethernet by socket, Our product support an agreement like that, but not standard RFC2217, it is more sample and easy than RFC2217.

1. When module receive setup command, if is a valid command(right packet head and right checksum), the module will change self setting and answer nothing, else the data bits would be sent out at com port.
2. TCP Client, TCP Server, UDP Client, UDP Server, UDP broadcast support this function.
3. All changes will work at once, but not save to module, when power off will lose the settings.

Set the software interface:

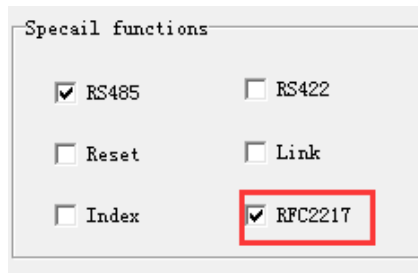

**Diagram5-8 RFC2217**

select it by default

The command length is 8 bits, detail as follow table. The demo bytes are in hex mode:

Name	Packet header	Band rate	UART bits setting	Check sum
Bytes	3	3	1	1
Description	Three bytes	Band rate in hex mode, High byte first.	Parity/data/stop settings, see follow table.	Check sum of last 4 bytes
For example (115200,N,8,1)	55 AA 55	01 C2 00	83	83
For example (9600,N,8,1)	55 AA 55	00 25 80	83	83

**Diagram5-9 RFC2217 introduce**

**Appendix:** UART bits setting detail.

Bit	Description	Value	Description
1:0	Data bits	00	5 bits
		01	6 bits
		10	7 bits
		11	8 bits
2	Stop bits	0	1 bits
		1	2 bits
3	Parity enable	0	Not enable Parity
		1	Enable Parity
5:4	Parity type	00	ODD
		01	EVEN
		10	Mark
		11	Clear
8:6	Not used	000	Please fill 0

**Diagram5-10 UART bits setting detail**

Test bits

55AA5501C2008346 For 115200 N,8,1

55AA550025808328 For 9600 N,8,1

Those two data is not transferred to serial, but the packet not conform will be transferred and revealed.



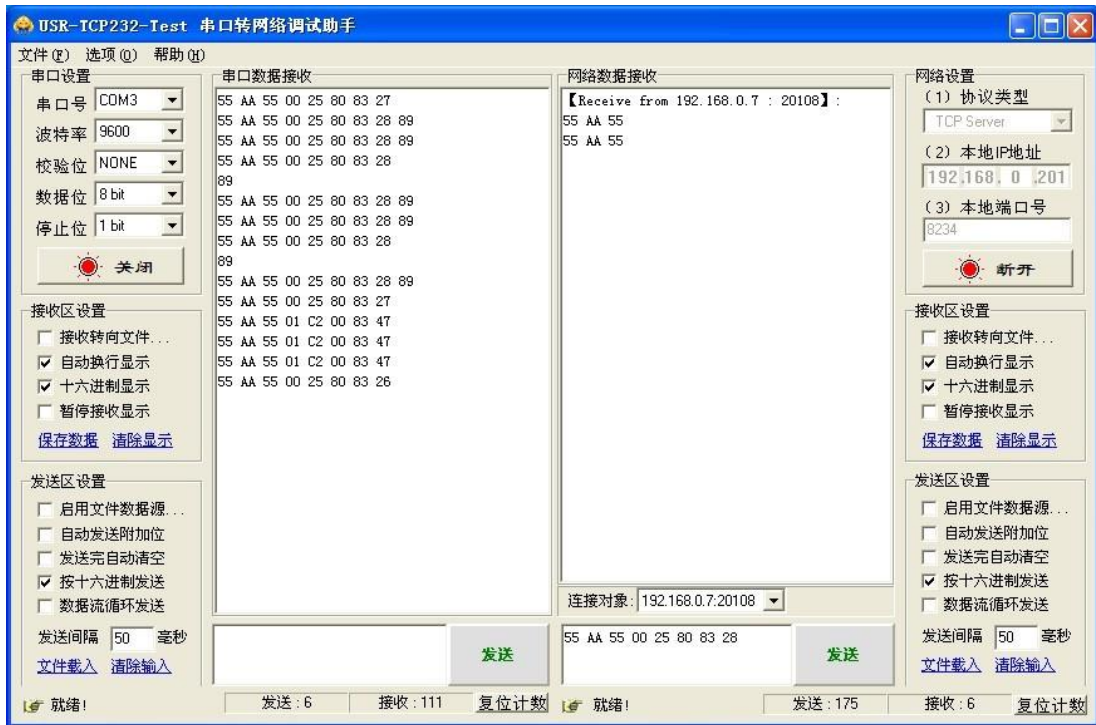

Diagram5-11 RFC2217 for test

Open this function then open RFC2217 via USR-VCOM so serial port baud rate of PC application software serial server device can be matched automatically.

## 6. Common Questions

### 6.1 Work Across Network Segment

If your USR-K1 device's IP is 192.168.0.7, and remote PC's IP is 192.168.1.7, we need to config.

Subnet mask of USR-K1 device, PC, and router to 255.255.0.0, if not, USR-K1 module will not communicate normally.

### 6.2 More Network Cards

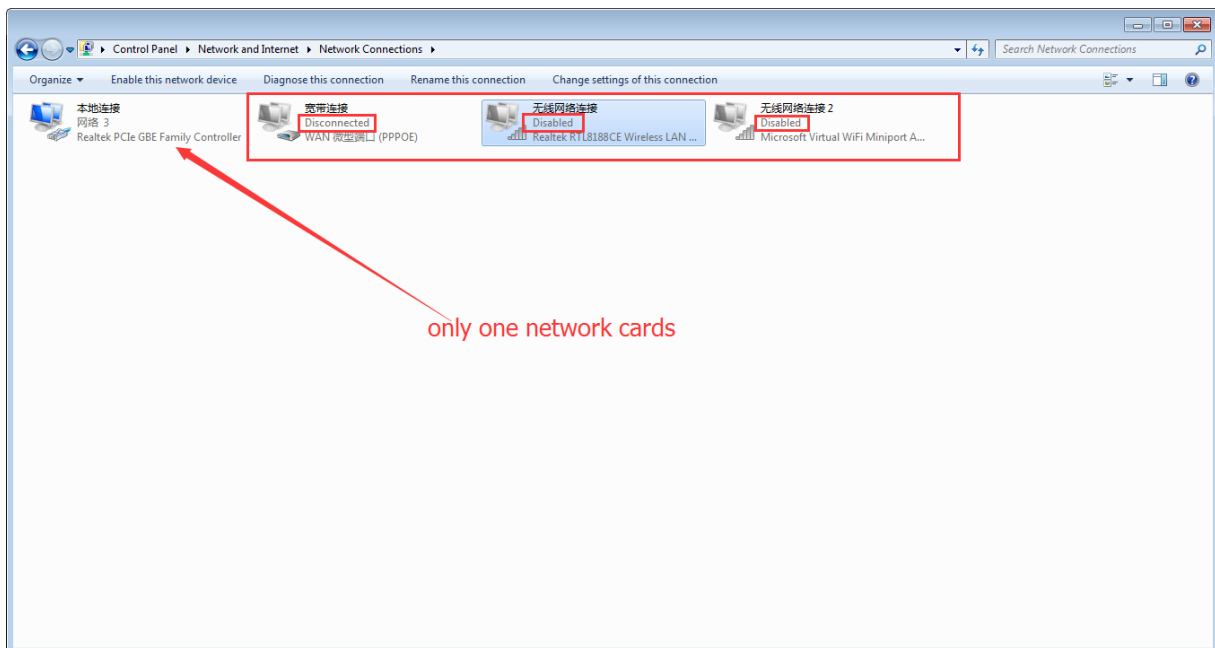

### 6.3 Every Period of Time, Module Dropped

1. Firewall is no disable and antivirus software isn't off.
2. The IP address conflict.
3. More network cards is open.
4. A power shortage or oversize ripple voltage.

## 6.4 Search Device Failure, Port Occupied

Open more one setup software ,close it.

## 7. Revision history

V1.0.1 New

V1.0.2 Adding details about RJ45 light

V1.0.3 Correct some errors

V1.0.4 Adress

## 8. Contact Us

Company: Jinan USR IOT Technology Limited  
Address: Floor 11,Building1,No.1166 Xinluo Street,Gaoxin Distric,Jinan,Shandong,250101 China  
Tel: 86-531-55507297, 86-531-88826739  
Web: <http://www.usriot.com>  
Support : <http://h.usriot.com>  
Email: [sales@usr.cn](mailto:sales@usr.cn)