

Serial to Ethernet module

(USR-TCP232-T, USR-TCP232-2)
(USR-TCP232-S, USR-TCP232-D)
(USR-TCP232-24, USR-TCP232-200)
(USR-TCP232-300, USR-TCP232-204)

File version: V3.2.5



Serial to Ethernet module USR-TCP232-T24 series is data transparent transmission equipment for convert TCP or UDP socket data to RS232 or RS485 or RS422, small size, low power, powered by ARM processors, high speed , high Stability.

Key words: TCP/IP, TCP, UDP, RS232, RS485, RS422, Ethernet, Module, Single chip card module, Serial server, Serial to Ethernet

There is discount for bulk purchase. And customized service is available, MOQ is 300 pics.

Jinan USR IOT Technology Limited provide you Ethernet, WIFI, GPRS Solutions and so on, hardware, software, and server. Just let me know your needs, we are going to satisfy.

Content

Serial to Ethernet module.....	1
1. Product introduction.....	5
1.1 Brief Intro.....	5
1.2 Function Features.....	5
1.3 Product Characteristics.....	5
1.4 Applications Area.....	6
1.5 Product Model.....	6
2. Product Test.....	7
2.1 Hardware Connection.....	7
2.2 Set-up Software.....	8
2.3 Communication Test.....	9
2.4 The Default Mode Test.....	9
2.5 Virtual COM Test.....	12
3. Hardware Description.....	14
3.1 USR-TCP232-S.....	14
3.1.1 Technical Specifications.....	14
3.1.2 Hardware Description.....	15
3.1.2.1 Pin Description.....	15
3.1.2.2 Mechanical Dimensions.....	16
3.1.2.3 Connection Diagram.....	16
3.2 USR-TCP232-T.....	19
3.2.1 Technical Specifications.....	19
3.2.2 Hardware Description.....	20
3.2.2.1 Pin description.....	20
3.2.2.2 LED Status.....	21
3.2.2.3 Mechanical Dimensions.....	21
3.2.2.4 Connection Diagram.....	21
3.3 USR-TCP232-W.....	22
3.3.1 Technical Specifications.....	23
3.3.2 Hardware Description.....	25
3.3.2.1 Pin description.....	25
3.3.2.2 LED Status.....	27
3.3.2.3 Mechanical Dimensions.....	27
3.3.2.4 Connection Diagram.....	27
3.4 USR-TCP232-D.....	28
3.4.1 Technical Specifications.....	28
3.4.2 Hardware Description.....	29
3.4.2.1 Pin Description.....	29
3.4.2.2 LED Status.....	29
3.4.2.3 Mechanical Dimensions.....	30
3.5 USR-TCP232-2.....	31

3.5.1	Technical Specifications	31
3.5.2	Hardware Description	32
3.5.21	Pin Description	32
3.5.22	Interface Description	32
3.5.23	Jumper Usage Mechanical Dimensions	33
3.6	USR-TCP232-200	34
3.7	USR-TCP232-24	34
3.7.1	Technical Specifications	35
3.7.2	Hardware Description	35
3.7.21	LED Status	35
3.7.22	Interface Description	36
3.7.23	Jumper Usage Mechanical Dimensions	37
3.8	USR-TCP232-300	38
3.9	USR-TCP232-301	39
3.9.1	Technical Specifications	39
3.9.2	Hardware Description	40
3.9.21	LED Status	40
3.9.22	Interface Description	40
3.9.23	Jumper Usage Mechanical Dimensions	41
3.10	USR-TCP232-204	42
3.10.1	Technical Specifications	42
3.10.2	Hardware Description	42
3.10.21	LED Status	42
3.10.22	Interface Description	43
3.10.23	Terminal Functional Specifications	43
3.10.24	Jumper Usage Mechanical Dimensions	44
4.	Work Mode	44
4.1	Block Diagram	44
4.2	TCP Client Mode	45
4.3	UDP Mode	45
4.4	UDP Server Mode	45
4.5	TCP Server Mode	46
4.6	Special Functions	47
4.61	RS485	47
4.62	Link	48
4.63	Reset	48
4.64	ID	48
4.65	Index	51
4.66	RFC2217	52
5.	Application	53
5.1	COM TCP/UDP server	53
5.2	Virtual COM	54
5.3	COM TCP/UDP COM	54
5.4	Many UDP server	55
5.5	TCP/UDP proxy server	55

5.6 TCP/UDP server.....	56
6. Configuration	58
6.1 Configure Command Format.....	58
6.11 Serial Settings Command	58
6.12 Network Settings Command	59
6.2 USR-TCP232-SETUP	60
6.21 Setup via COM.....	60
6.22 Setup via Net.....	60
6.23 Special Function Configuration	61
7. Contact us.....	62

1. Product introduction

1.1 Brief Intro

USR-TCP232-T24 series is used to TCP network packet or UDP packet with the micro-controller/RS232/RS485/RS422 interface data transparent transmission equipment. The product is equipped with ARM processors, high speed, high stability. Module class of compact size, low power consumption; server refined aluminum metal shell, compression, anti-drop, anti-interference performance.

USR-TCP232-T24 series is more functional embedded Ethernet serial port data conversion products, it has built-in TCP/IP protocol stack, the user can use it easily to complete embedded devices network function, save manpower material resources and development time, make our products faster to market, enhance competitiveness.

There is 10/100M auto detected RJ45 interface, serial communication baud rate up to 230.4Kbps, can work at TCP Server, TCP Client, UDP and UDP server mode, setup easily via software.

1.2 Function Features

- 10/100M auto detect interface;
- support AUTO MDI/MDIX(Except for TCP232-W, -301), Can use a crossover cable or parallel cable connection;
- RS232 bound rate can set up from 300 to 256000;
- RS485 bound rate can set up from 300 to 115200;
- Work mode TCP Server, TCP Client, UDP, UDP Server;
- Working model related parameters can be set via a serial port or network;
- 3.3 V TTL level (module products);
- Virtual serial port supported;
- Unique heartbeat package mechanism to ensure that the connection is reliable, put an end to connect feign death;
- Under UDP mode, Packet Broadcast is prohibited, with stronger anti-interference ability;
- across the gateway, across switches, routers;
- Can work in LAN, also can work on the Internet (external network);
- Transmission distance: RS232 - 15 meters, RS485 - 1000 meters, cable 200 meters (after the switches together through the Internet, no distance limit).

1.3 Product Characteristics

- 32 bits ARM CPU inside;
- LAN : 10/100Mbps; protect: Built-2KV isolated electromagnetic;
- serial port baud rate: from 2400 to 256 KBPS can be set up, and up to 3 MBPS;
- network protocol: ETHERNET ARP IP UDP TCP ICMP;
- Software tool: configuration software, TCP/UDP test soft, RS232 debug soft;
- Configuration method: RS232 or via Ethernet, free software available;

- Operating temperature: -25~75°C;
- Storage environment: -40~85°C, 5~95%RH.

1.4 Applications Area

Serial device server module for connecting serial industrial automation equipment such as PLC, sensors, meters, motors, drives, bar code readers and displays and design.

Serial server module is widely used in attendance, access control systems, Canteen machines, POS systems, building control, fire control, the banking system, engine room monitoring, UPS monitoring, power, oil, environmental monitoring, industrial applications and other areas.

T24 Series products are suitable for internal LAN users in a simple to use, for complex network environments such as the Internet, a camera, a large group networks, fiber to Ethernet, etc., it is recommended to use E45 series.

1.5 Product Model

Model number	Power supply DC	Interface	Network port 10/100Mbps	Package Type (Module products)
USR-TCP232-S	3.3V	TTL	PHY chip network interface	Stamp Hole Package
USR-TCP232-T	3.3V	TTL	Take 2kv magnetic isolation RJ45	Pin package (DIP package)
USR-TCP232-D	3.3V	TTL	With 1.5KV PHY signal of electromagnetic separation	Pin package (DIP package)
USR-TCP232-2	5V power adapter/terminal	RS232	Take 2 kv magnetic isolation RJ45	
USR-TCP232-200	5V power adapter/terminal	RS232	Take 2 kv magnetic isolation RJ45	
USR-TCP232-24	5V power adapter/terminal	RS232/RS485	Take 2 kv magnetic isolation RJ45	
USR-TCP232-300	5V power adapter/terminal	RS232/RS485	Take 2 kv magnetic isolation RJ45	
USR-TCP232-204	5V power adapter/terminal	RS485	Take 2 kv magnetic isolation RJ45	

Model Description: USR stands for Jinan USR IOT Technology Limited as well as our brand. TCP232 is TCPIP to serial module product, 2/4/T means serial-side level in the form.

2. Product Test

Pls connect the product with your computer or router to test its performance.

2.1 Hardware Connection

USR-TCP232-S, USR-TCP232-T, USR-TCP232-D are named as the module, USR-TCP232-2, USR-TCP232-200, USR-TCP232-24, USR-TCP232-300, USR-TCP232-204, the serial server in the following:

1. Power Supply:

The module's VDD is DC5V, and its VCC is DC3V3. Only choose one to ensure supply current more than 200mA. The serial server needs matching adapter for power.

2. Serial Connection:

The module' serial level is TTL. It needs converter TTL to RS232 if connected to RS232 serial of computer. (The module can direct to computer with our evaluation kit.)

The serial server can connect to computer directly.(RS485 level needs to convert to RS232).

3. Network Connection:

Connect to computer or join your router via cable. The product can realize automatic switch between connected directly cable and crossover.

USR-TCP232-T connected to computer as below:

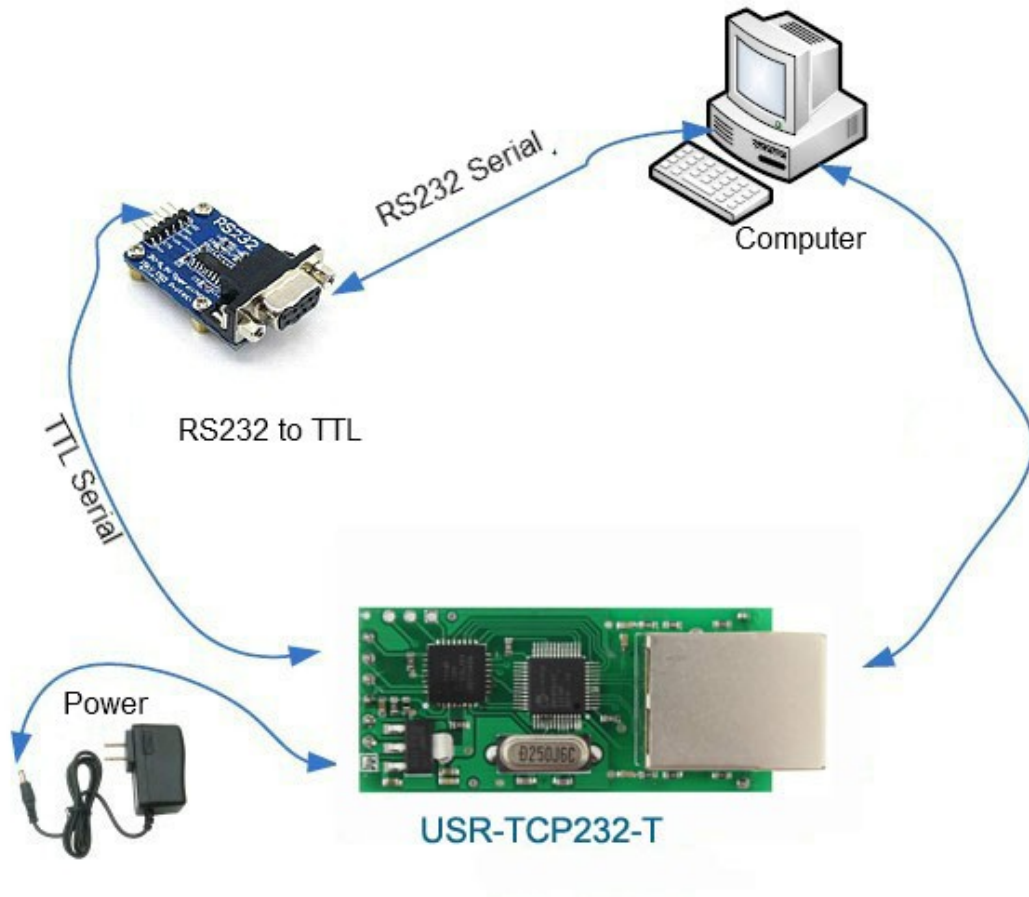

2.2 Set-up Software

Set-up Software in the CD as  **USR-TCP232-Setup** can help to view default setting then set the parameter.

1. Setup via net (Firstly, ensure the computer IP is static. The module IP is 192.168.0.201by default; Disable firewall, antivirus program and WIFI).

Set via COM (Connect CFG pin).

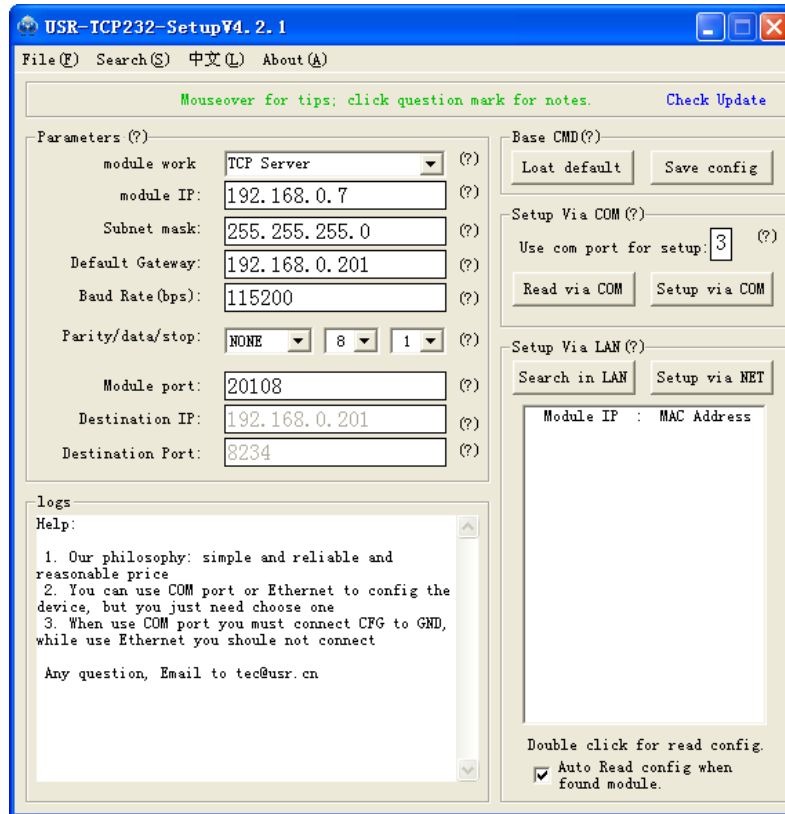

2.3 Communication Test



in CD can help you test.

Serial to net debugging tester application:

1. Ensure the COM port baud rate, check bits, data bits, stop bit correspond to module parameters.
2. Ensure network protocol, IP address, port number correspond to module parameters.
3. Open COM and the web then connect. They begin transparent transmission after choose the module IP.

2.4 The Default Mode Test

The default mode is TCP Client, and the default parameter is as below:

IP address: 192.168.0.7

Checksum: 255.255.255.0

Gateway: 192.168.0.201

Baud rate: 115200

Destination IP: 192.168.0.201

Destination port: 8234

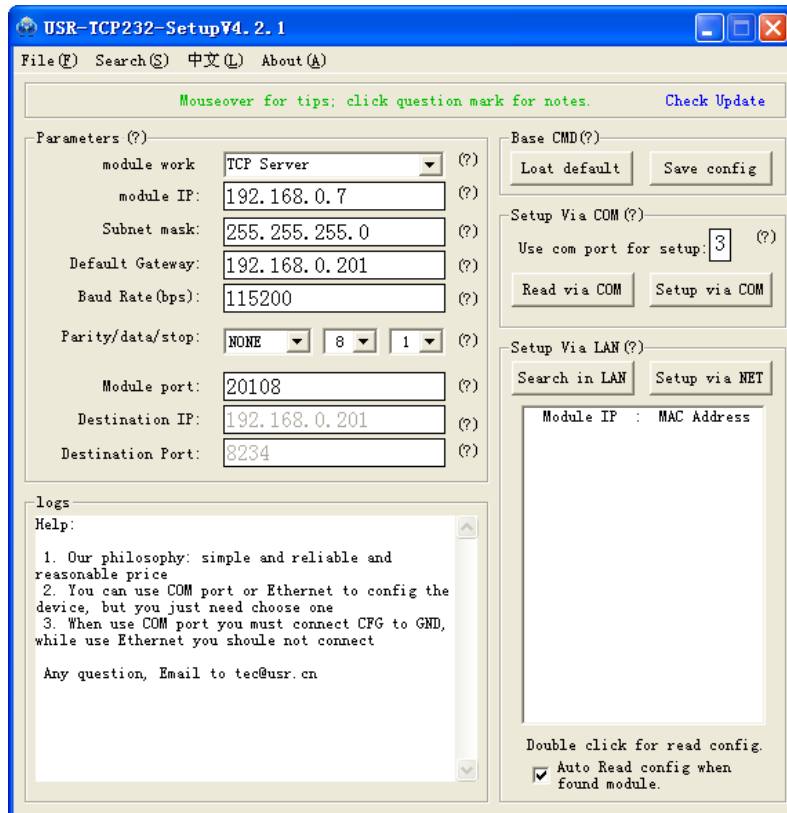

1. Material: pc with rs232(or use USB to rs232 cable), 3.3V or 5V power, rs232 cable, Network Cable, COM debug software, TCP/IP debug software(in CD, also can be download).
2. Connection: Connect module rs232 to pc rs232, RJ45 to pc RJ45 or the same router (same subnet).
Power on the module.
Note: TXD to RXD, RXD to TXD.
3. Setup PC IP to 192.168.0.201.



USR-TCP232-Test.exe

4. Open the  in CD, TCP server, listen port 8234

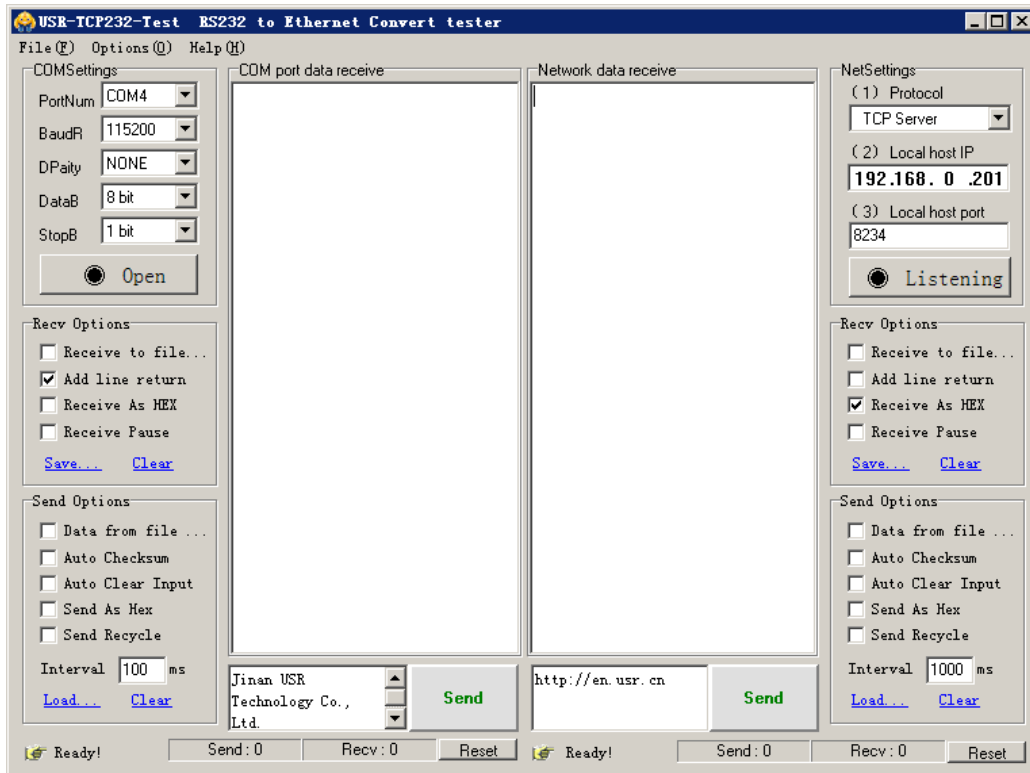

5. Set the baud rate 115200 and right port, then open COM port.

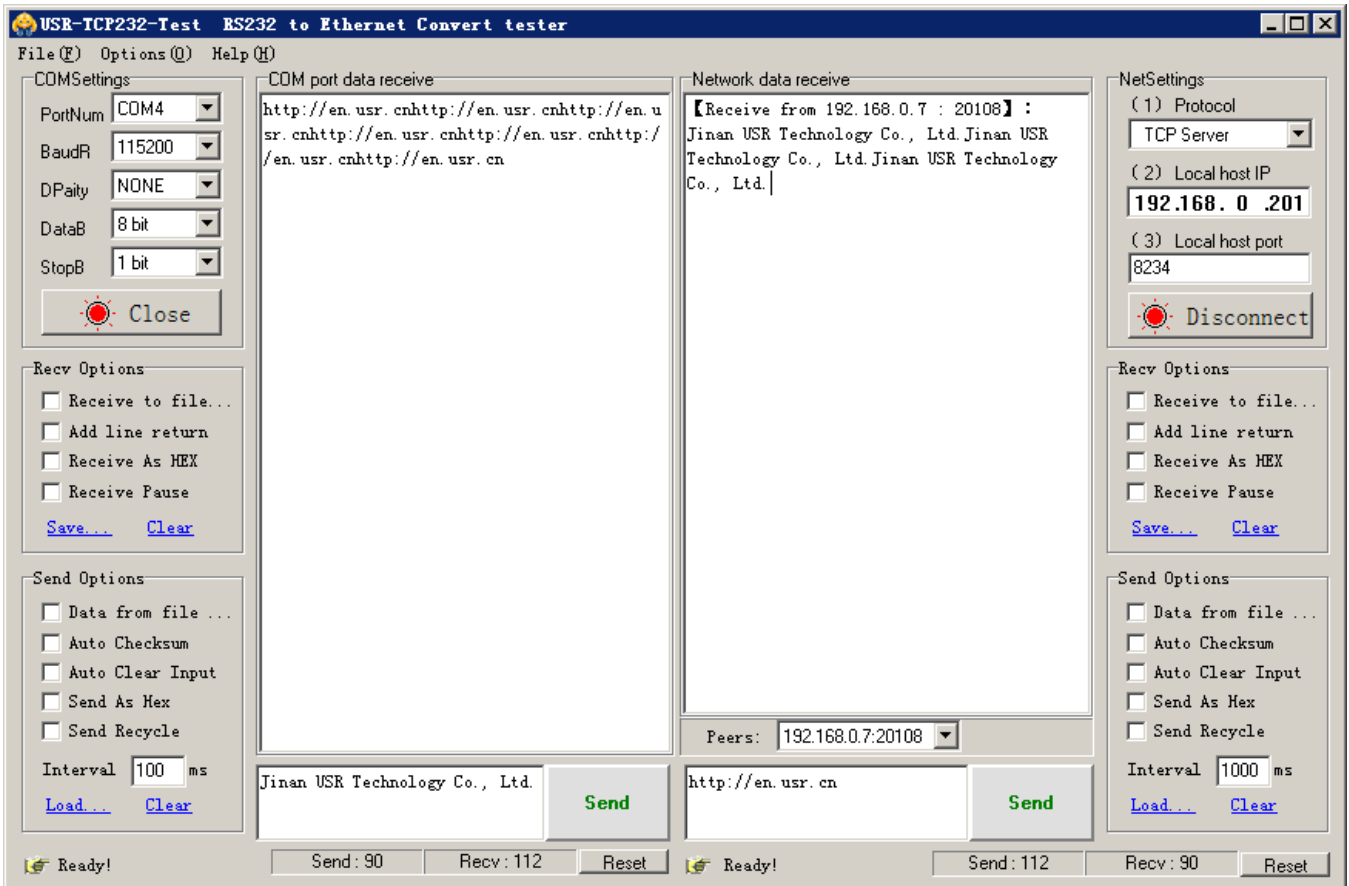

6. The module can connect the port automatically regarding to TCP Client mode. Quickly, you see that , then Choose the peers, type info and click send. The info will be sent to the module then output from the COM.

7. You can send data between two softwares.

Serial to PC: PC Serial->Module Serial->Module Network->PC Network

Network to Serial: PC Network->Module Network->Module Serial->PC Serial

2.5 Virtual COM Test

Virtual COM means to convert data TCP connected to data of a COM within PC for transparent transmission. Take TCP Client mode for example:

1. Connect module to PC serial and set PC IP to be 192.168.0.201.

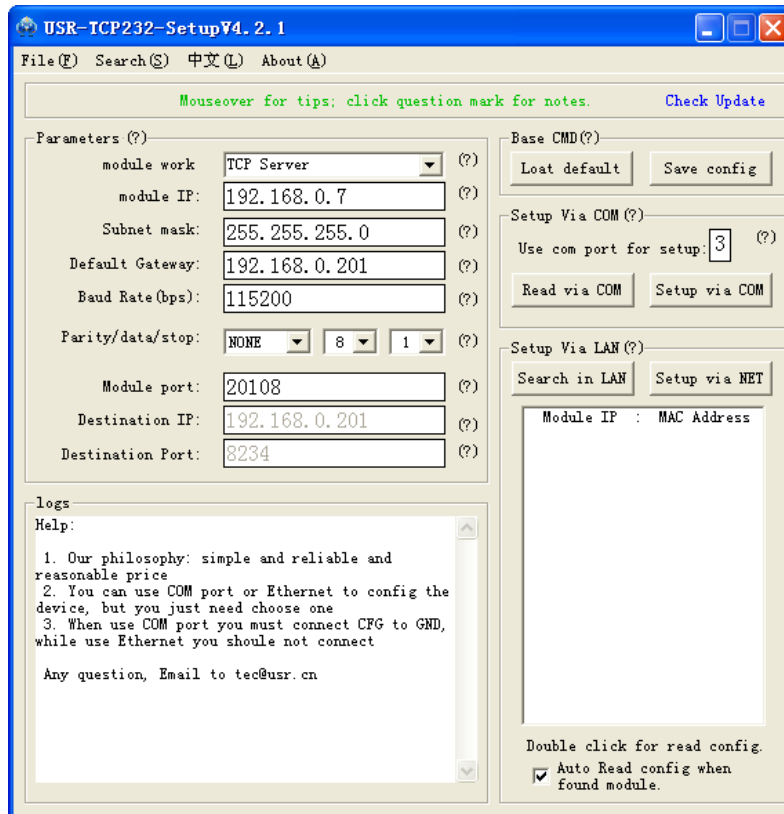

2. Install



and run

问题

Add virtual COM, you need to notice COM port, bond rate and work mode of PC, then click Activate.

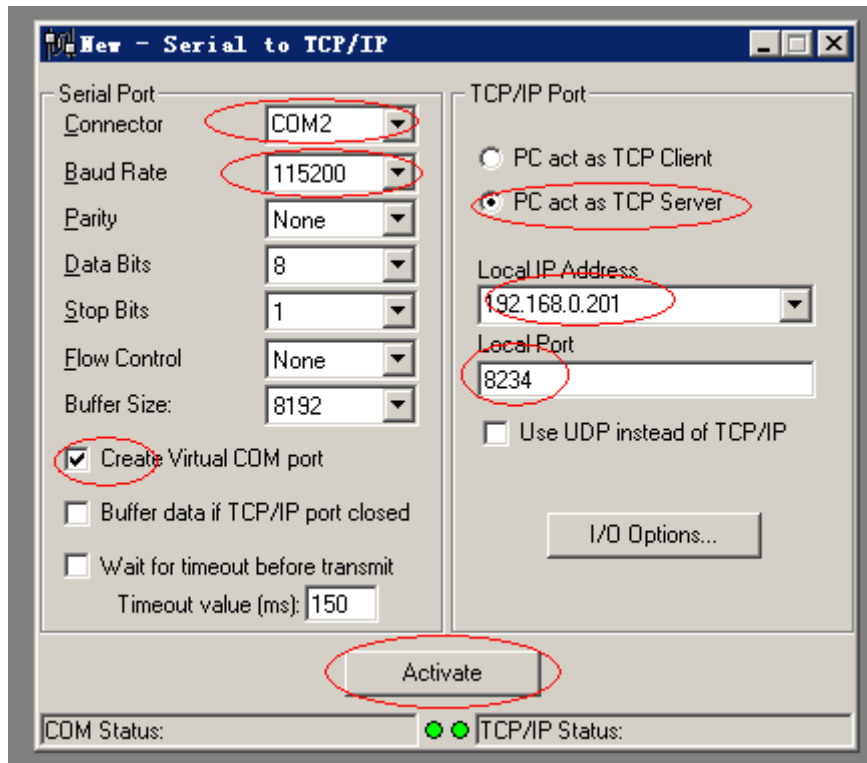

5. After Activate click, COM2, will be created, it receives data from TCPIP socket. And data sent to COM2 is transmitted to TCP232 converter then output through RS232.

The success picture as follow:

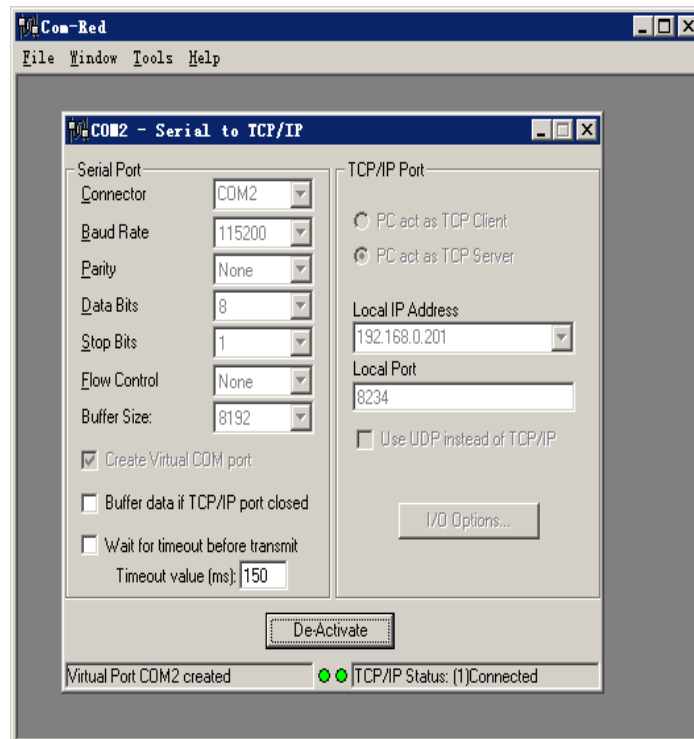

At this point, you can use your equipment as an ordinary serial port, and operate of local virtual serial port will converted to operation of the remote module RS232. The figure is show send data between the two serial port.

3. Hardware Description

3.1 USR-TCP232-S

USR-TCP232-S Model Stamp Hole Package TTL serial port level, the PHY signal, the small size of the TCP/IP serial protocol module.

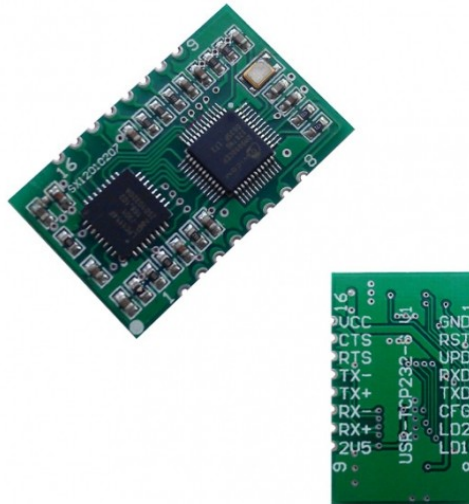

3.1.1 Technical Specifications

Major characteristic	Parameter
Package Type	Stamp hole encapsulation (SMD encapsulation)
Schematic diagram and PCB library	See the CD library file
Power Supply	VCC: 3.3 V DC typical values, minimum 3.15, the biggest 3.45 V, suitable for 3.3 V microcontroller system (If it is 5 v, reference Fig 1-1 3.3V-5V Matching circuit)
Serial port level	TTL level
Network interface	PHY signal
Physical Size:	PCB size: 33*20mm (L*W)
Temperature and humidity range	Operating temperature: -25 to 75 ° C Storage temperature: -40 to 80 ° C Storage humidity: 5% to 95% RH

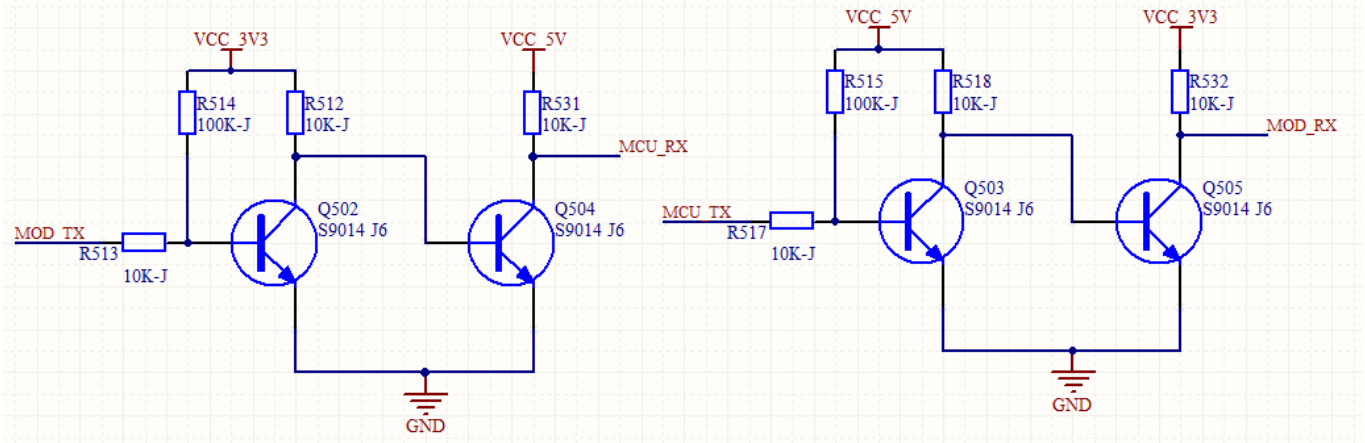

Fig 1-1 3.3V-5V Matching circuit

3.1.2 Hardware Description

3.1.2.1 Pin Description

No.	Pin	Function	Descriptions
1	GND	Signal ground	GND
2	RST	RESET	Pin received 200ms low to reset the whole module. If you do not use, can be suspended. Note: The module is powered automatic reset, it is recommended that connect the MCU IO port, reset the MCU control module in a particular case.
3	ISP	Update pin	This pin to ground to the module power module can be upgraded. If you do not use, can be suspended.
4	RXD	Module data is received	Data receiving end of the module, TTL level 3.3V microcontroller(If it is 5 v, reference Fig 1-1 3.3V-5V Matching circuit)
5	TXD	Module data transmission	Data transmission end of the module, TTL level can be connected to 3.3V microcontroller(If it is 5 v, reference Fig 1-1 3.3V-5V Matching circuit)
6	CFG	Serial ports Configuration pins	Low, you can use the serial port module configuration. Normal working hours left floating or tied HIGH. Note: give the power module, and then pulled down the CFG pin to enter the serial configuration state.
7	LED2	Network data instructions	Network data indicator LED connected to VCC, without the current limiting resistance (module existing)
8	LED1	Network connection	Network connection status indicator LED connected to VCC,

		status indicator	without the current limiting resistor (module already)
9	2V5	PHY chip Output voltage	PHY chip to control the voltage output, access networks transformer center tap
10	RX+	Received signal +	Receive Data+
11	RX-	Received signal -	Receive Data-
12	TX+	Transceiver Data+	Transceiver Data+
13	TX-	Transceiver Data-	Transceiver Data-
14	RTS	the alternate pin	Can be used as RS485 enable pin
15	CTS	the alternate pin	Can be used as a network connection status indicator pin
16	VCC	Power supply	Power supply: 3.3V @ 200mA

3.1.22 Mechanical Dimensions

Unit: mm

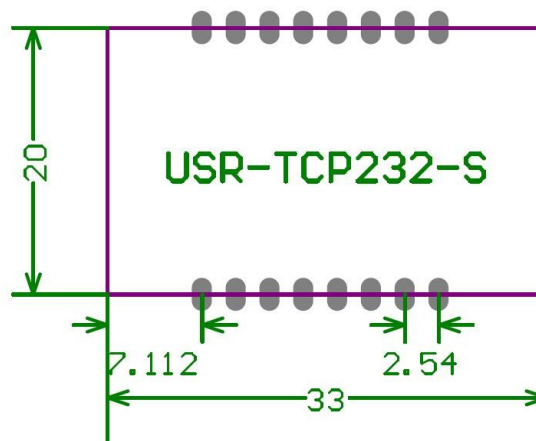

3.1.23 Connection Diagram

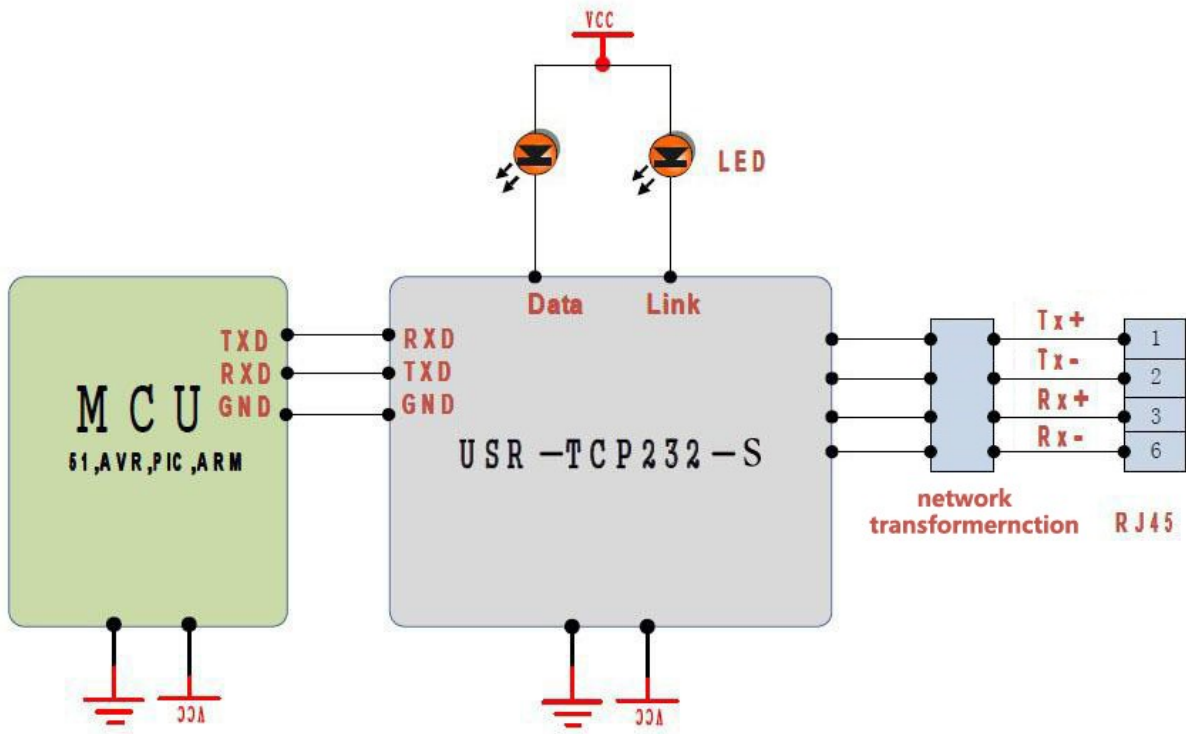

USR-TCP232-S+RJ45 of built-in network transformer:

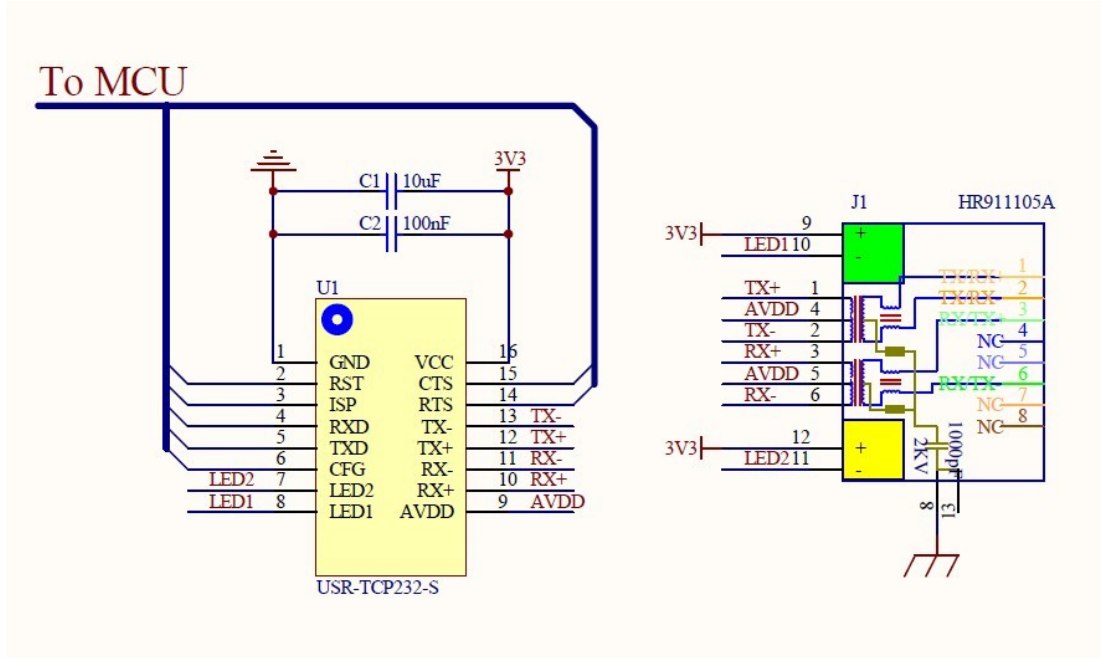

USR-TCP232-S+RJ45 of built-in network transformer:

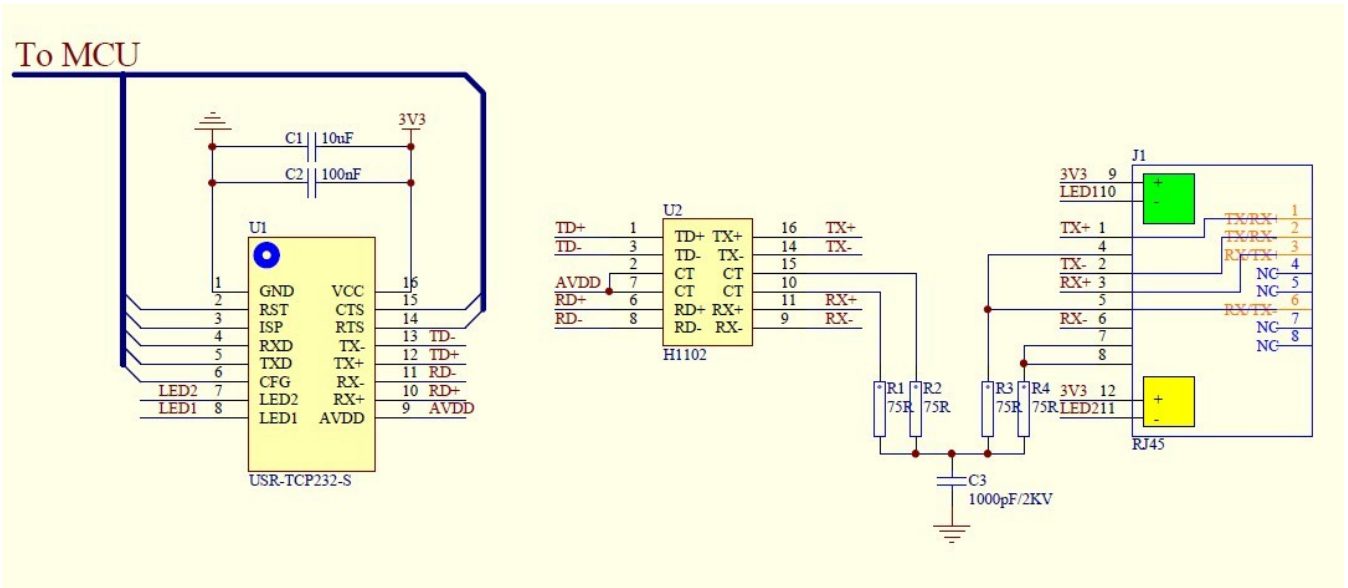

3.2 USR-TCP232-T

USR-TCP232-T Model pin package, TTL serial port level, of 2KV electromagnetic isolation RJ45 interface, small size TCP/IP serial protocol module.



3.2.1 Technical Specifications

Major characteristic	Parameter
Package Type	Pin type package (DIP package)
Schematic diagram and PCB library	See the CD library file
Power Supply	The module adopts double power supply interfaces, either is ok. VCC: 3.3 V DC typical values, minimum 3.15, the biggest 3.45 V, suitable for 3.3 V microcontroller system VDD: 5 V DC typical values, minimum 4.5, the biggest 5.5 V (If it is 5 v, reference Fig 1-1 3.3V-5V Matching circuit)
Working current	150 mA, the maximum 200 mA
Serial port level	TTL level
Network interface	PHY signal
Physical Size:	PCB size: 50.5*22.6mm (L*W) Module size: 55*23*23mm (L*W*H)
Temperature and humidity range	Operating temperature: -25 to 75 ° C Storage temperature: -40 to 80 ° C Storage humidity: 5% to 95% RH

3.2.2 Hardware Description

3.2.21 Pin description

Pin	Name	Description
VDD	Power 1	4.5~5.5V
VCC	Power 2	3.3V
GND	GND	Power and Communications Ground
RST	Reset pin	200ms GND reset the module
TXD	UART transmission pin	TTL-3.3V(If it is 5 v, reference Fig 1-1 3.3V-5V Matching circuit)
RXD	UART receive pin	TTL-3.3V(If it is 5 v, reference Fig 1-1 3.3V-5V Matching circuit)
CFG	Configure pin	Configure mode when this pin GND, normal mode when VCC or idle



Module in the upper left four spare pins from right to left:

Pin	Name	Description
1: EN	EN alternate pin	RS485 enable pin
2: LINK	LINK alternate pin	Network connectivity status indicator pin
3: ISP	Update pin	This pin to ground to the module power module can be upgraded.

3.2.22 LED Status

There are two leds in RJ45 connector, one is green, and the other is yellow.

LED	Name	Description
Green	Link state	Light when 100Mbps network linked
Yellow	Data transfer	Blink when there is data in or out

3.2.23 Mechanical Dimensions

Unit: mm

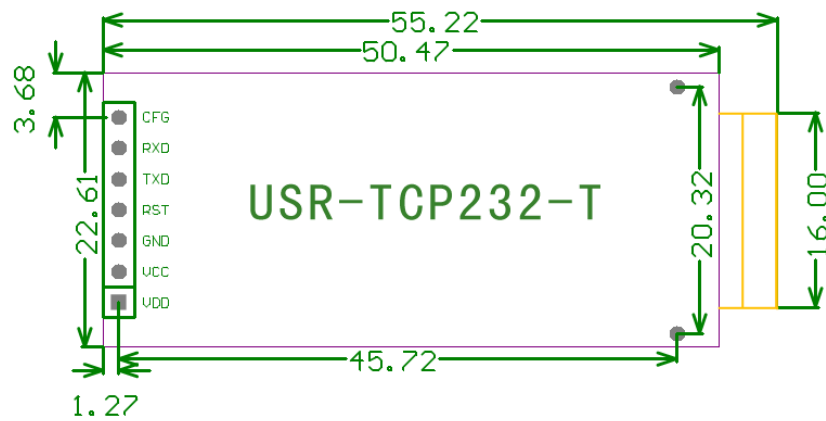

3.2.24 Connection Diagram

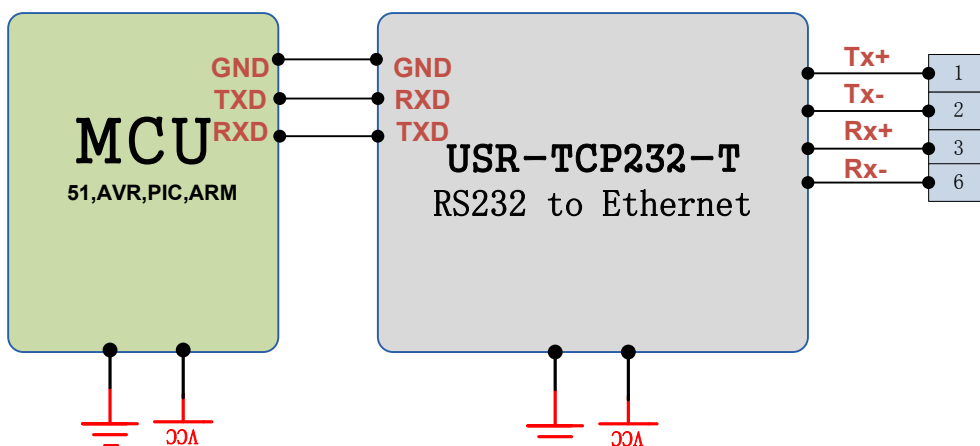

3.3 USR-TCP232-W

USR-TCP232-T Model pin package, TTL serial port level, of 2KV electromagnetic isolation RJ45 interface, small size TCPIP serial protocol module.

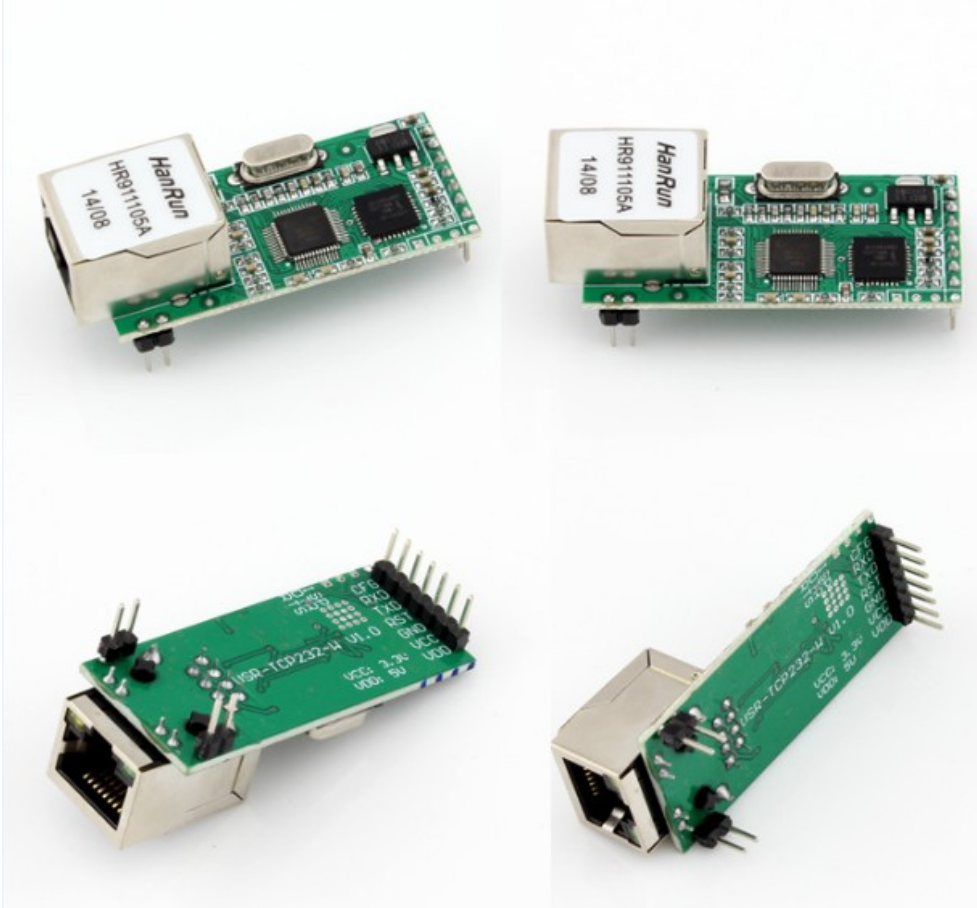

Size of -W is fully compatible to -T, except one place(add one more pin), shown below

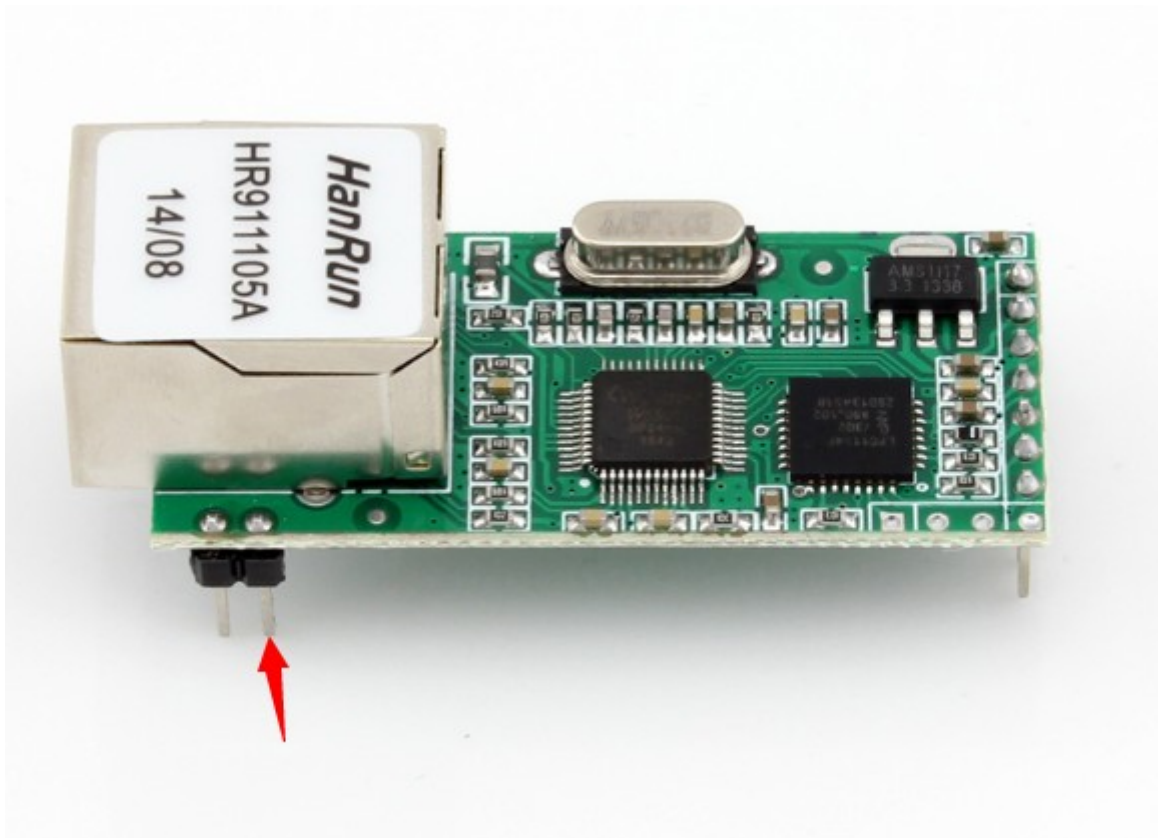

3.3.1 Technical Specifications

Major characteristic	Parameter
Package Type	Pin type package (DIP package)
Schematic diagram and PCB library	See the CD library file
Power Supply	The module adopts double power supply interfaces, either is ok. VCC: 3.3 V DC typical values, minimum 3.15, the biggest 3.45 V, suitable for 3.3 V microcontroller system VDD: 5 V DC typical values, minimum 4.5, the biggest 5.5 V, (If it is 5 v, reference Fig 1-1 3.3V-5V Matching circuit)
Working current	Around 140 mA when working fullspeed, the maximum 200 mA
Serial port level	TTL level
Network interface	PHY signal
Physical Size:	PCB size: 50.5*22.6mm (L*W) Module size: 55*23*23mm (L*W*H)
Temperature and humidity range	Operating temperature: -45 to 85 ° C Storage temperature: -40 to 85 ° C

	Storage humidity: 5% to 95% RH
--	--------------------------------

3.3.2 Hardware Description

3.3.2.1 Pin description

Pin	Name	Description
VDD	Power 1	4.5~5.5V
VCC	Power 2	3.3V
GND	GND	Power and Communications Ground
RST	Reset pin	200ms GND reset the module
TXD	UART transmission pin	TTL-3.3V(If it is 5 v, reference Fig 1-1 3.3V-5V Matching circuit)
RXD	UART receive pin	TTL-3.3V(If it is 5 v, reference Fig 1-1 3.3V-5V Matching circuit)
CFG	Configure pin	Configure mode when this pin GND, normal mode when VCC or idle

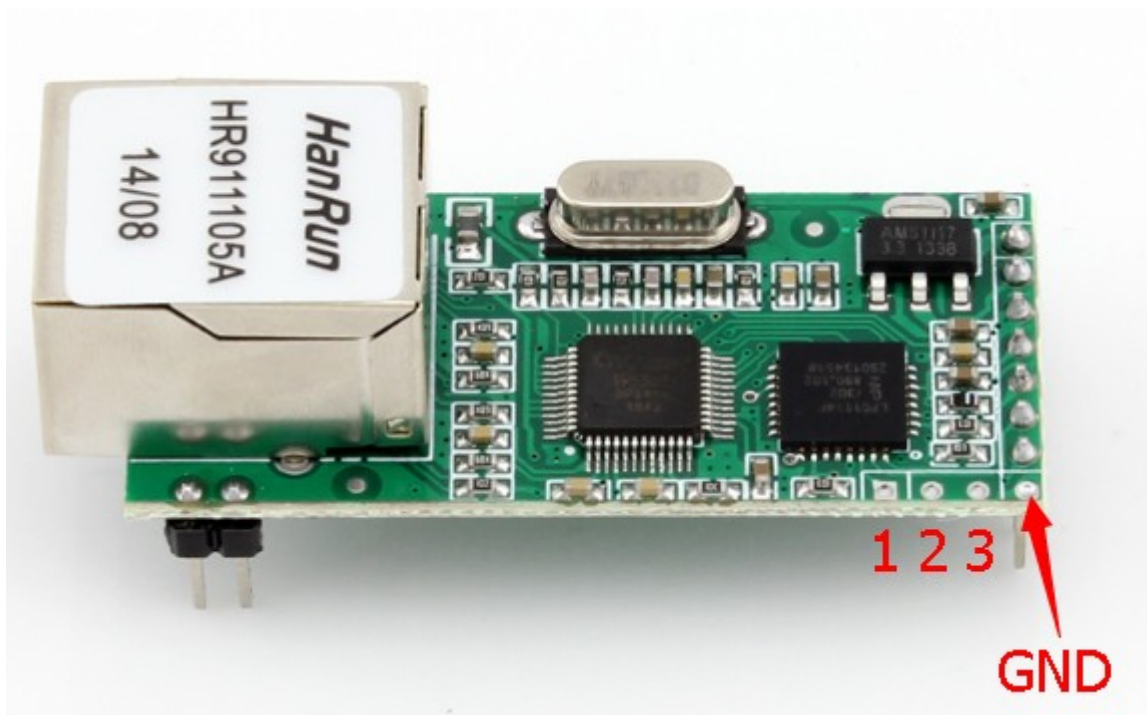

Pin	Name	Description
1: EN	EN alternate pin	RS485 enable pin
2: LINK	LINK alternate pin	Network connectivity status indicator pin
3: ISP	Update pin	This pin to ground to the module power module can be upgraded.

3.3.22 LED Status

There are two leds in RJ45 connector, one is green, and the other is yellow.

LED	Name	Description
Green	Link state	Light when 100Mbps network linked
Yellow	Data transfer	Blink when there is data in or out

3.3.23 Mechanical Dimensions

Unit: mm

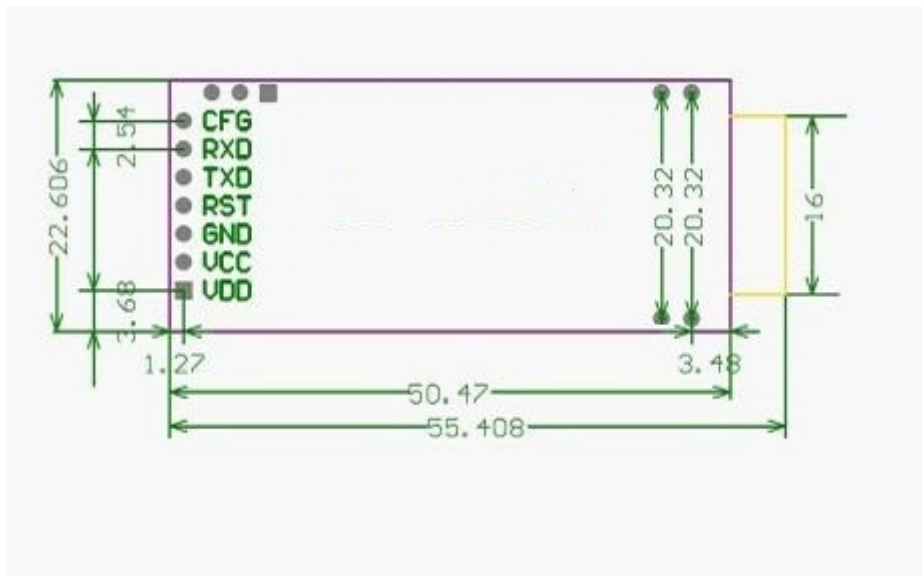

3.3.24 Connection Diagram

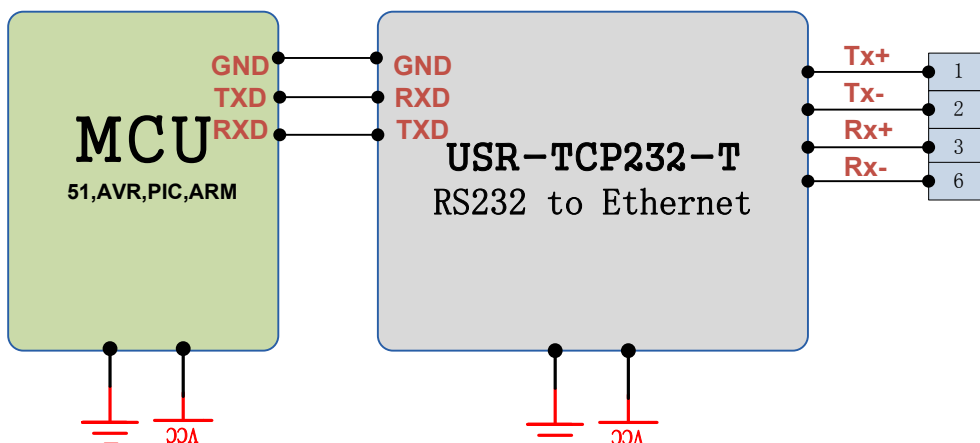

3.4 USR-TCP232-D

USR-TCP232-D models to pin package, TTL serial port level, 1.5KV electromagnetic isolation PHY signal, small size, TCPIP compatible weeks meritorious product serial protocol module.

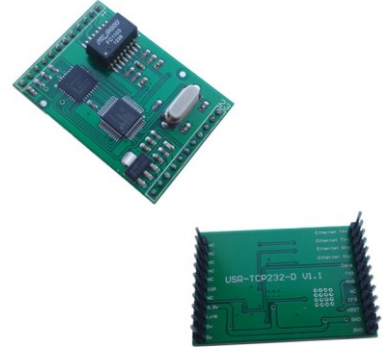

3.4.1 Technical Specifications

Major characteristic	Parameter
Package Type	Pin type package (DIP package)
Schematic diagram and PCB library	See the CD library file
Power Supply	The module adopts double power supply interfaces, either is ok. VCC: 3.3 V DC typical values, minimum 3.15, the biggest 3.45 V, suitable for 3.3 V microcontroller system VDD: 5 V DC typical values, minimum 4.5, the biggest 5.5 V, (If it is 5 v, reference Fig 1-1 3.3V-5V Matching circuit)
Serial port level	TTL level
Network interface	PHY signal with 1.5KV Ethernet signal
Characteristic	Pin compatible ZLG products
Physical Size:	PCB size: 44*32mm (L*W) Module size: 44*32*15.4mm (L*W*H)
Temperature and humidity range	Operating temperature: -25 to 75 ° C Storage temperature: -40 to 80 ° C Storage humidity: 5% to 95% RH

3.4.2 Hardware Description

3.4.21 Pin Description

Pin	Name	Description	Pin	Name	Description
1	TX+	Transceiver Data+	A breach here		
2	TX-	Transceiver Data-	23	NC	
3	RX+	To RJ45 Pin3	22	NC	
4	RX-	To RJ45 Pin6	21	NC	
5	Data_LED	Link to yellow Led and through a resistance to VCC	20	NC	
6	TXD	Transmit data	19	NC	
7	RXD	Receive data	18	ISP	For Update
8	RTS	RS485 enable pin	17	NC	
9	CFG	Config enable port for RS232 Config	16	3.3V	DC3.3V input and 5V use 1 is ok.
10	RST	Reset pin, 200ms low for reset	15	LINK	Link to green Led and Through a resistance to VCC
11	GND	To GND	14	5V	DC5V input@200mA
12	GND	To GND	13	5V	DC5V input@200mA

3.4.22 LED Status

USR-TCP232-D Red LED, If the indicator is energized, the module power input is correct.

3.4.23 Mechanical Dimensions

Unit: mm

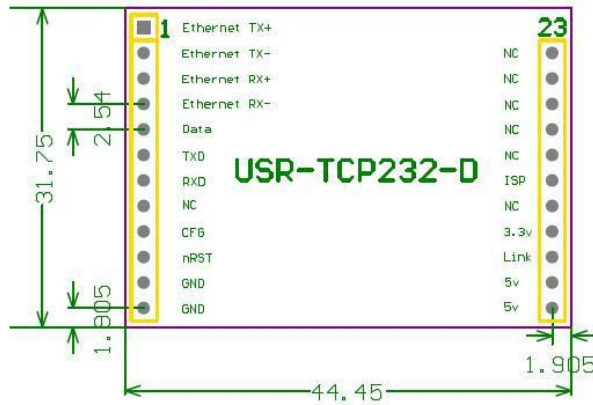

3.4.24 Connection Diagram

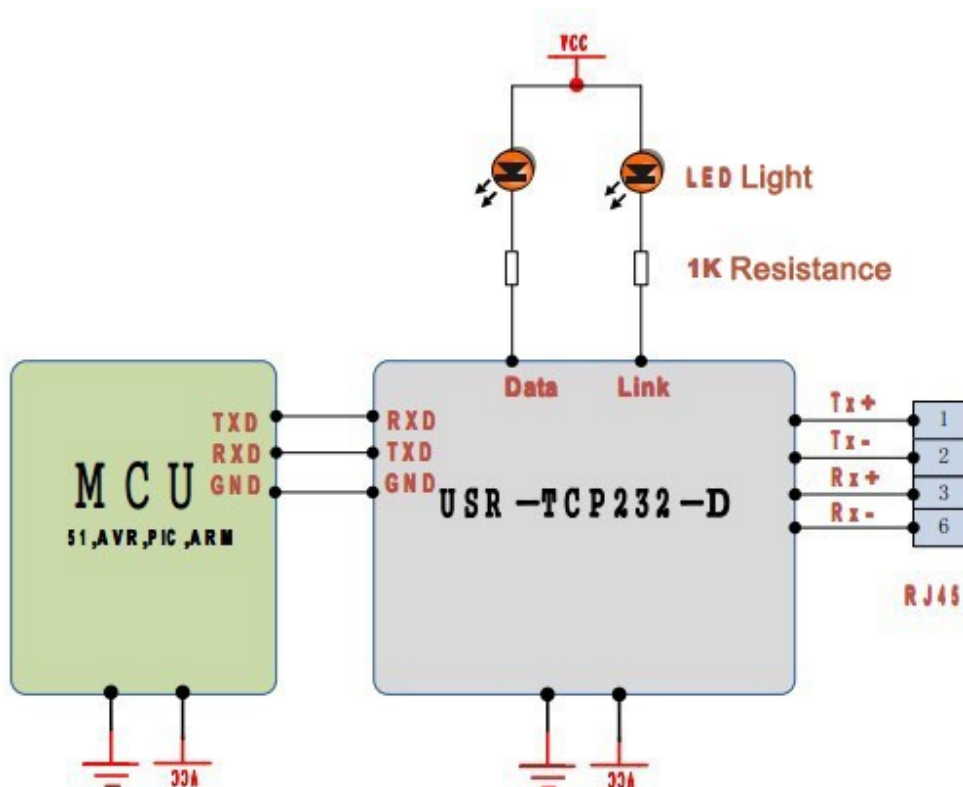

Note: Isolation transformer has been on this module, so you need not to add Isolation transformer in your RJ45 port.

3.5 USR-TCP232-2

USR-TCP232-2 Model is RS232 level, 2KV electromagnetic isolation RJ45 connector, 5.5 * 2.1 standard power supply or terminal power supply serial server.

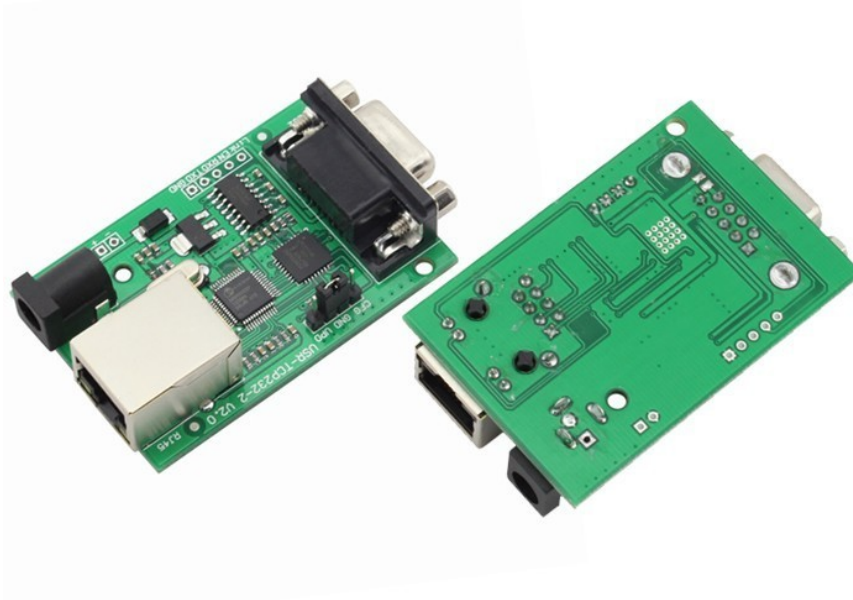

3.5.1 Technical Specifications

Major characteristic	Parameter
Power Supply	DC5V@1A power adapter
Serial port level	RS232
Network interface	RJ45 ports with 2KV electromagnetic isolation
Physical Size:	PCB size: 67.3*34mm(L*W) Product size: 86.6*34*25mm (L*W*H)
Temperature and humidity range	Operating temperature: -25 to 75 ° C Storage temperature: -40 to 80 ° C Storage humidity: 5% to 95% RH

3.5.2 Hardware Description

3.5.2.1 Pin Description

There are two leds in RJ45 connector, one is green, and the other is yellow. And 1 power led.

LED	Name	Description
Red	Power	Light When Power on
Green	Link state	Light when 100Mbps network linked
Yellow	Data transfer	Blink when there is data in or out

3.5.2.2 Interface Description

Power Interface

DC5V power supply, you can make 5.5 * 2.1 standard power supply or 3.81mm pitch terminal blocks, the default state is 5.5 * 2.1 standard power supply, power input with TVS protection products.

RS232 Interface

RS232 use 9 pin female (hole), only 3 pins in use, others are NC, the detail is below.

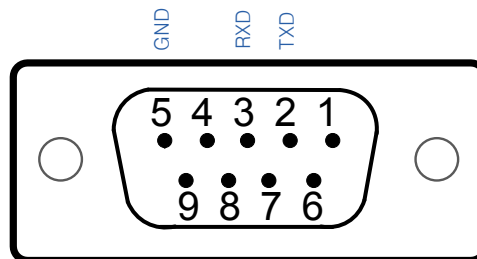

ID	Mark	Function	Description
2	TXD	Send Device Data	RS232 Level
3	RXD	Receive Device Data	RS232 Level
5	GND	Ground	Communication total site
9	VCC	Device is powered via this pin	The PCB pads jumper need it with the power input a positive connection for the serial sensor supply via the serial line or external power to the device is not turned on by default.

RJ45 Internet Interface

Auto detected 10M/100M RJ45 interface, support AUTO MDI/MDIX, that is to say you can use crossover cable or a straight cable to connect it to PC for test.

Pin	Name	Description
1	TX+	Transceiver Data+
2	TX-	Transceiver Data-
3	RX+	Receive Data+
4	n/c	Not connected
5	n/c	Not connected
6	RX-	Receive Data-
7	n/c	Not connected
8	n/c	Not connected

3.5.23 Jumper Usage Mechanical Dimensions

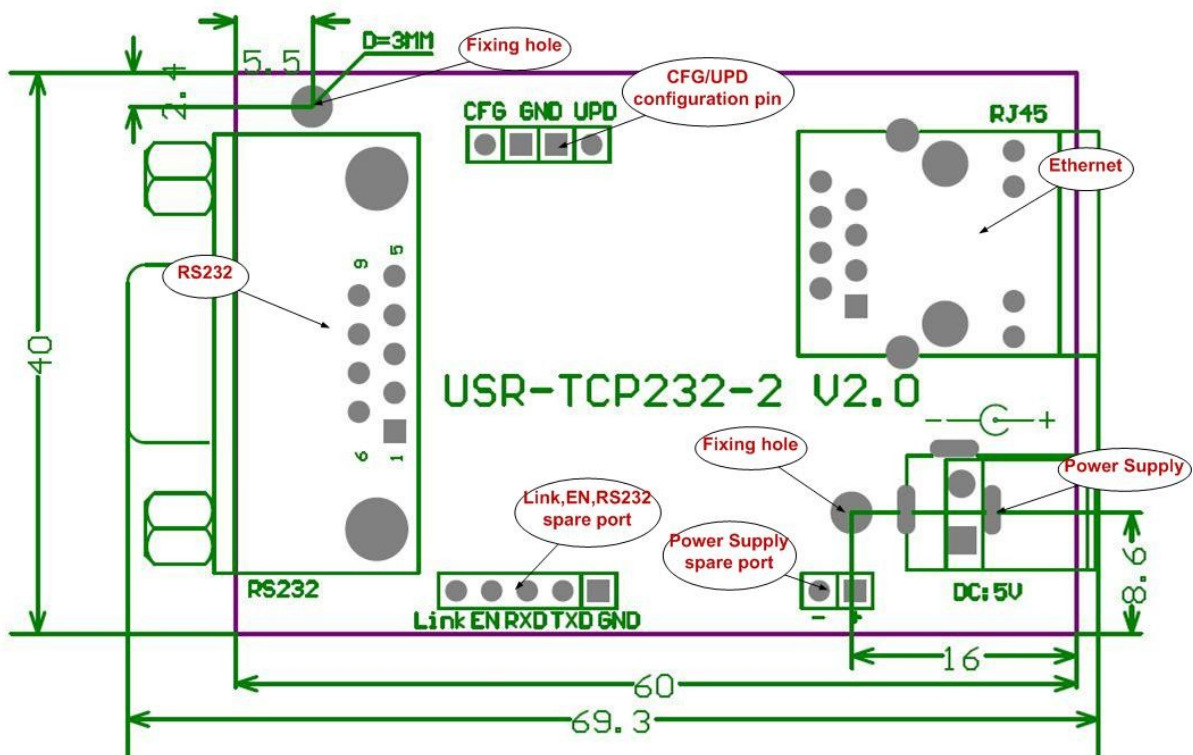

Mini Jumper Marks:

Short CFG and GND is CFG, effective, using serial for configuration.

Short UPD and GND is UPD, effective, coming to upgrade.

Mini Jumper links to GND by default, not effective.

Link, EN function, pls refer to 4.6 Special functions Description.

3.6 USR-TCP232-200

USR-TCP232-200 Model RS232 level, the 2KV electromagnetic isolation RJ45 interface, 5.5 * 2.1 standard power supply or terminal power supply serial server.

Appearance and size shown as follows:

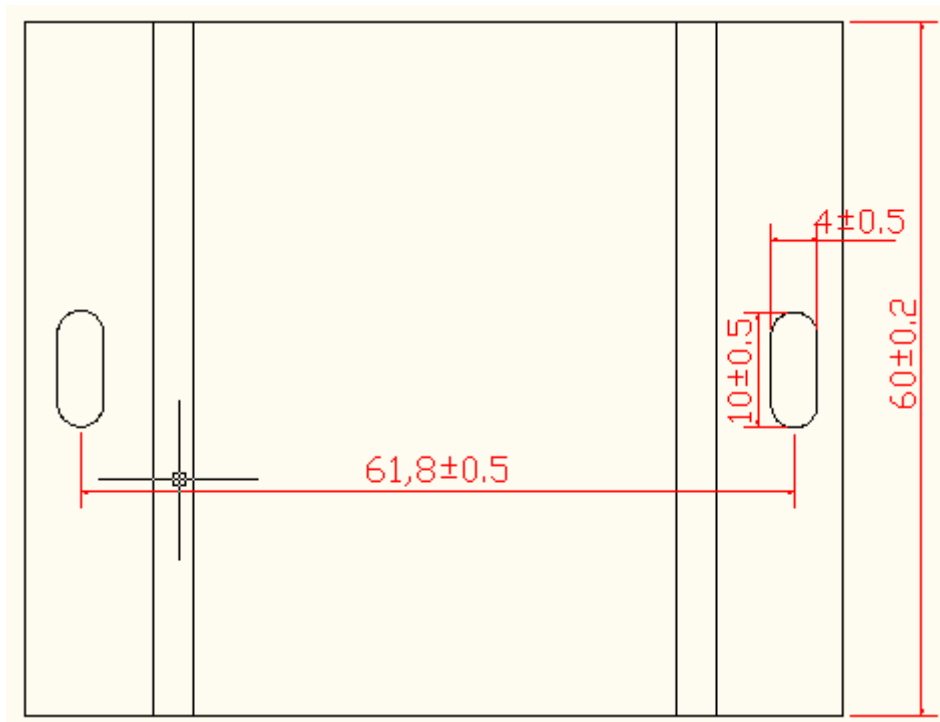

3.7 USR-TCP232-24

USR - TCP232-24 models for RS232 or RS485 level, 2 kv RJ45 interface of electromagnetic isolation, 5.5 * 2.1 standard power supply serial server.

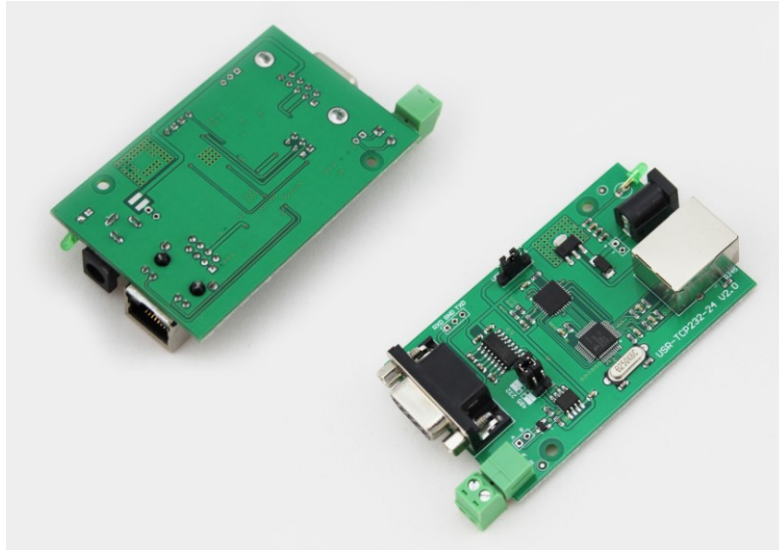

3.7.1 Technical Specifications

Major characteristic	Parameter
Power Supply	DC5V@1A power adapter
Serial port level	RS232 RS485
Network interface	RJ45 ports with 2KV electromagnetic isolation
Physical Size:	PCB size: 80*50mm(L*W) Product size: 89.2*50*23mm (L*W*H)
Temperature and humidity range	Operating temperature: -25 to 75 ° C Storage temperature: -40 to 80 ° C Storage humidity: 5% to 95% RH

3.7.2 Hardware Description

3.7.2.1 LED Status

There are two leds in RJ45 connector, one is green, and the other is yellow. And 1 power led.

LED	Name	Description
Green	Power	Light When Power on
Green	Link state	Light when 100Mbps network linked
Yellow	Data transfer	Blink when there is data in or out

3.7.22 Interface Description

Power interface

DC5V power supply, you can make 5.5 * 2.1 standard power supply, power input with TVS protection products.

RS232 interface

RS232 use 9 pin female (hole), only 3 pins in use, others are NC, the detail is below.

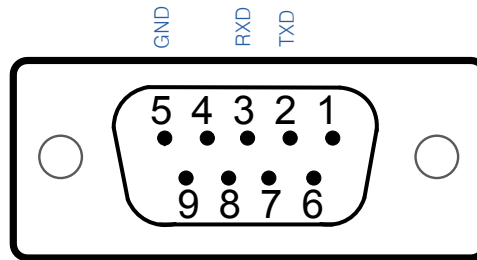

ID	Mark	Function	Description
2	TXD	Send Device Data	RS232 Level
3	RXD	Receive Device Data	RS232 Level
5	GND	Ground	Communication total site
9	VCC	Device is powered via this pin	The PCB pads jumper need it with the power input a positive connection for the serial sensor supply via the serial line or external power to the device is not turned on by default.

RS485 interface

RS485 has two lines A(data+) and B(data-), 120 Ohms Termination Resistance on board.

Note:

RS232 and RS485 can not work together, since it is 1 channel.

this module can autoselect for RS232 or RS485, doesn't need choose via jumper(from hardware version V3.0)

RJ45 internet interface

Auto detected 10M/100M RJ45 interface, support AUTO MDI/MDIX, that is to say you can use crossover cable or a straight cable to connect it to PC for test.

Pin	Name	Description
-----	------	-------------

1	TX+	Transceiver Data+
2	TX-	Transceiver Data-
3	RX+	Receive Data+
4	n/c	Not connected
5	n/c	Not connected
6	RX-	Receive Data-
7	n/c	Not connected
8	n/c	Not connected

3.7.23 Jumper Usage Mechanical Dimensions

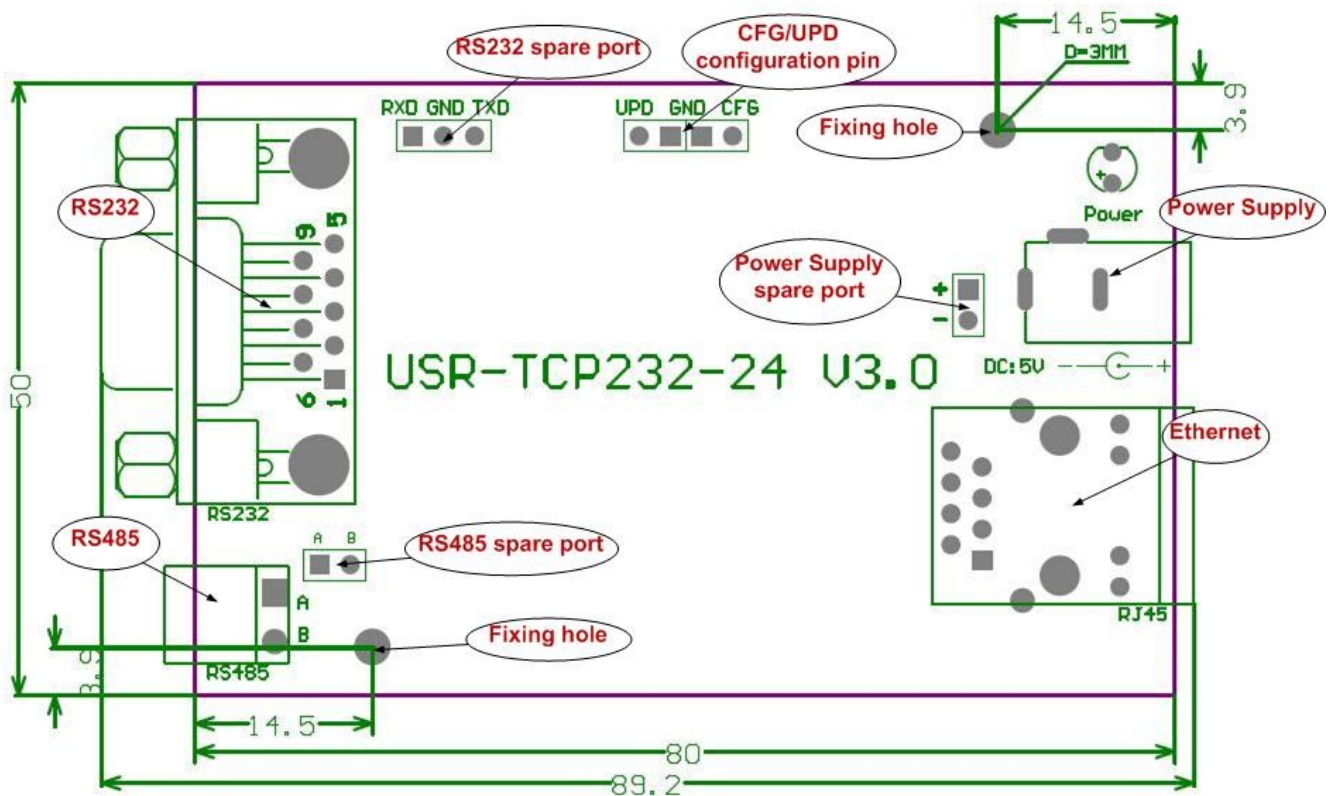

Mini Jumper Marks:

Short CFG and GND is CFG, effective, using serial for configuration.

Short UPD and GND is UPD, effective, coming to upgrade.

Mini Jumper links to GND by default, not effective.

3.8 USR-TCP232-300

USR-TCP232-300 model products for RS232 or RS485 level, 2 kv RJ45 interface of electromagnetic isolation, 5.5 * 2.1 standard power supply with a shell of a serial port server.

Appearance and size shown as follows:

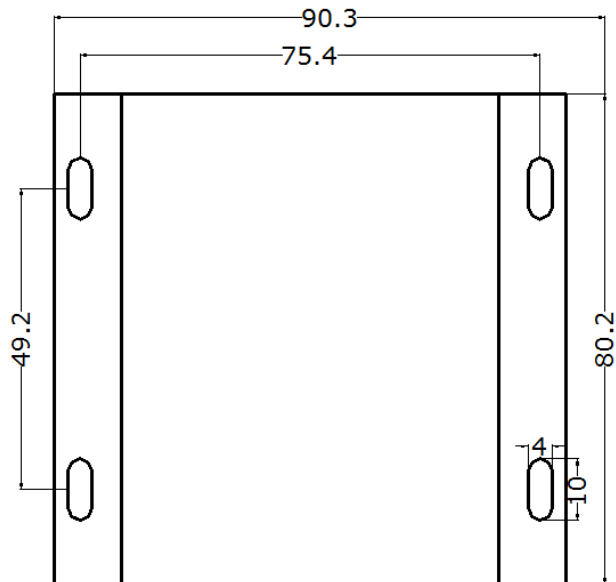

USR-TCP232-300 by USR-TCP232-24 shell, its specification please see USR-TCP232-24.

3.9 USR-TCP232-301

USR - TCP232-24 models for RS232 or RS485 level, 2 kv RJ45 interface of electromagnetic isolation, 5.5 * 2.1 standard power supply serial server.

The one with case, named as TCP232-301, footprint is fully compatible with TCP232-300

The one without case, named as TCP232-301M, footprint is fully compatible with TCP232-24

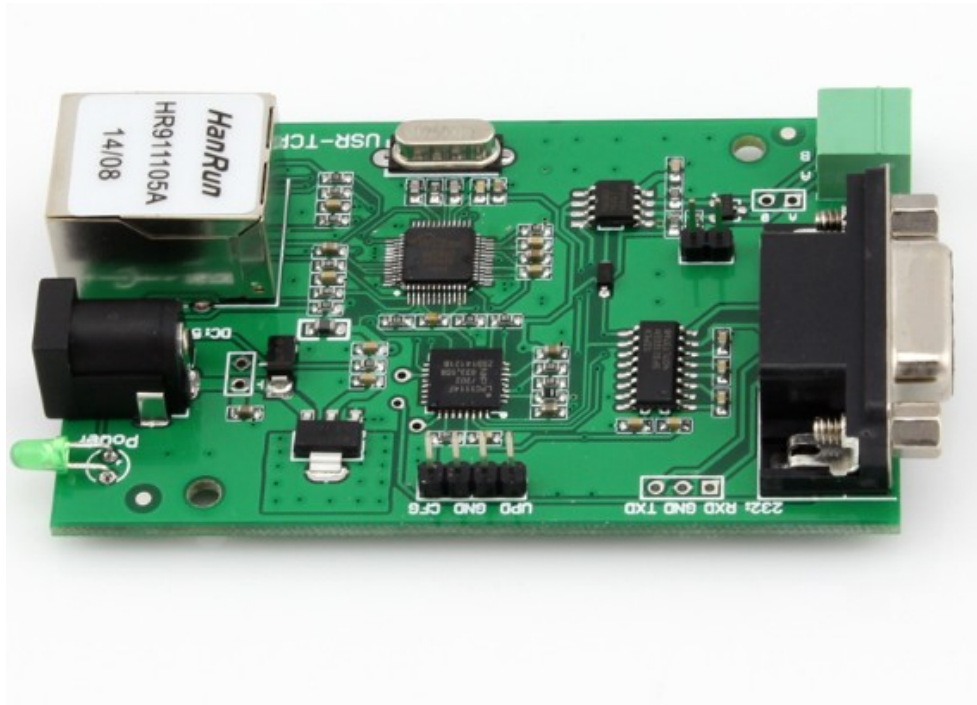

3.9.1 Technical Specifications

Major characteristic	Parameter
Power Supply	DC5V@1A power adapter
Serial port level	RS232 RS485
Network interface	RJ45 ports with 2KV electromagnetic isolation
Physical Size:	PCB size: 80*50mm(L*W) Product size: 89.2×50×23mm (L*W*H)
Temperature and humidity range	Operating temperature: -45 to 85 ° C Storage temperature: -45 to 85 ° C Storage humidity: 5% to 95% RH

3.9.2 Hardware Description

3.9.21 LED Status

There are two leds in RJ45 connector, one is green, and the other is yellow. And 1 power led.

LED	Name	Description
Green	Power	Light When Power on
Green	Link state	Light when 100Mbps network linked
Yellow	Data transfer	Blink when there is data in or out

3.9.22 Interface Description

Power interface

DC5V power supply, you can make 5.5 * 2.1 standard power supply, power input with TVS protection products.

RS232 interface

RS232 use 9 pin female (hole), only 3 pins in use, others are NC, the detail is below.

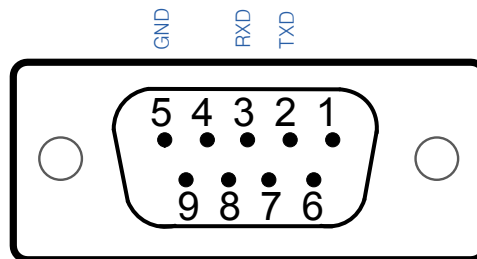

ID	Mark	Function	Description
2	TXD	Send Device Data	RS232 Level
3	RXD	Receive Device Data	RS232 Level
5	GND	Ground	Communication total site
9	VCC	Device is powered via this pin	The PCB pads jumper need it with the power input a positive connection for the serial sensor supply via the serial line or external power to the device is not turned on by default.

RS485 interface

RS485 has two lines A(data+) and B(data-), 120 Ohms Termination Resistance on board.

Note: this module user Jumpers to change work for RS232 or RS485, by default it work at RS232 mode.

RJ45 internet interface

Auto detected 10M/100M RJ45 interface, doesn't support AUTO MDI/MDIX.

Pin	Name	Description
1	TX+	Transceiver Data+
2	TX-	Transceiver Data-
3	RX+	Receive Data+
4	n/c	Not connected
5	n/c	Not connected
6	RX-	Receive Data-
7	n/c	Not connected
8	n/c	Not connected

3.9.23 Jumper Usage Mechanical Dimensions

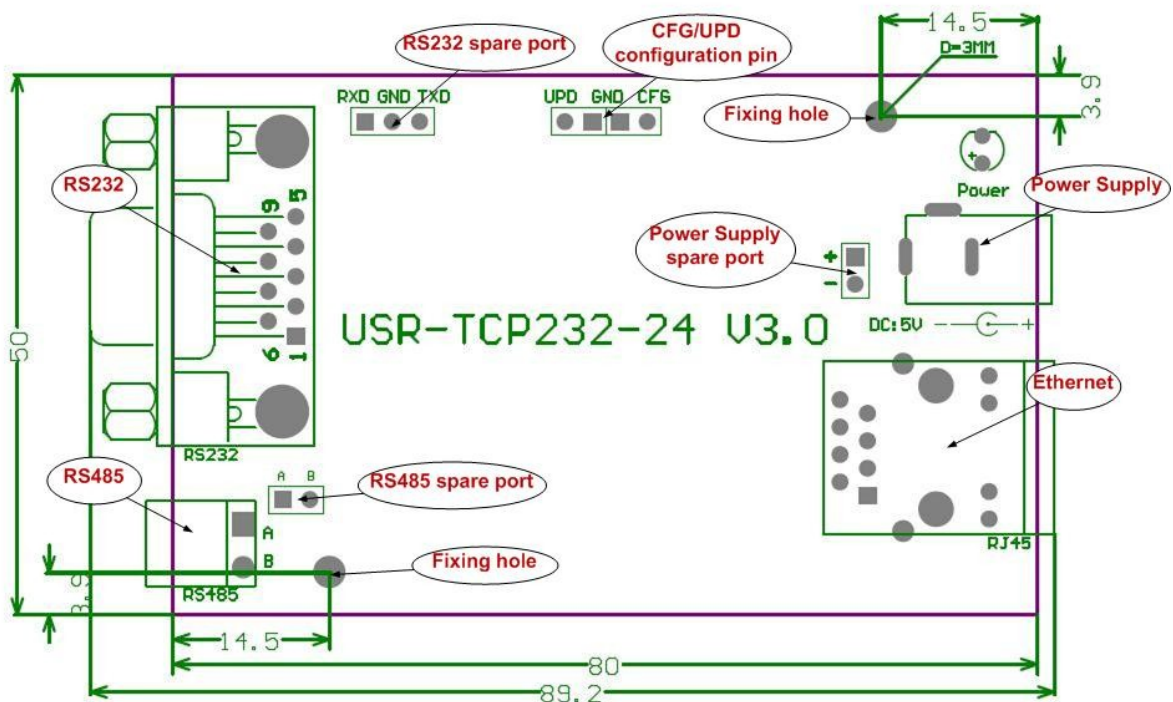

Mini Jumper Marks:

Short CFG and GND is CFG, effective, using serial for configuration.

Short UPD and GND is UPD, effective, coming to upgrade.

Mini Jumper links to GND by default, not effective.

3.10 USR-TCP232-204

USR-TCP232-204 model products for RS485, 2 kv RJ45 interface of electromagnetic isolation, 5.5 * 2.1 standard power supply or power supply terminal of a serial port server with shell.



3.10.1 Technical Specifications

Major characteristic	Parameter
Power Supply	DC5-18Vpower adapter
Serial port level	RS485
Network interface	RJ45 ports with 2KV electromagnetic isolation
Physical Size:	PCB size: 80*50mm(L*W) Product size: 95*85*25mm (L*W*H)
Temperature and humidity range	Operating temperature: -25 to 75 ° C Storage temperature: -40 to 80 ° C Storage humidity: 5% to 95% RH

3.10.2 Hardware Description

3.10.21 LED Status

There are two leds in RJ45 connector, one is green, and the other is yellow. And 1 power led.

LED	Name	Description
Green	Link state	Light when 100Mbps network linked

Yellow	Data transfer	Blink when there is data in or out
--------	---------------	------------------------------------

3.10.22 Interface Description

Power interface

DC5V power supply, you can make 5.5 * 2.1 standard power supply and 3.81mm pitch terminal blocks, power input with TVS protection products.

RS485 interface

RS485 has two lines A(data+) and B(data-),the signal terminal 0.5A PTC Resettable Fuse, to prevent accidental high current burn out the motherboard; Professional TVS lightning protection circuit design; Internal 120R terminal matching resistor (the default is not used, the available short cap configured to use); Can allow up to 32 transceiver node connected to the bus.

RJ45 internet

Auto detected 10M/100M RJ45 interface, support AUTO MDI/MDIX.

3.10.23 Terminal Functional Specifications



Pin	Name	Description
1	GND	GND
2	B(-)	B(data-)
3	A(+)	A(data+)

3.10.24 Jumper Usage Mechanical Dimensions

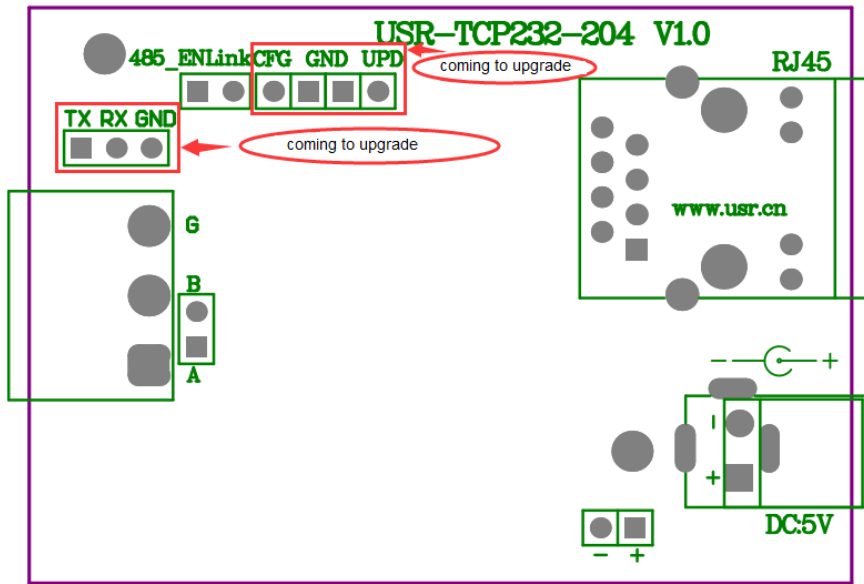

Mini Jumper Marks:

1. Short UPD and GND is UPD, effective, coming to upgrade.
Mini Jumper links to GND by default, not effective.
2. RS485 terminal resistance is not included by default, short Mini Jumper with according pin.

4. Work Mode

4.1 Block Diagram

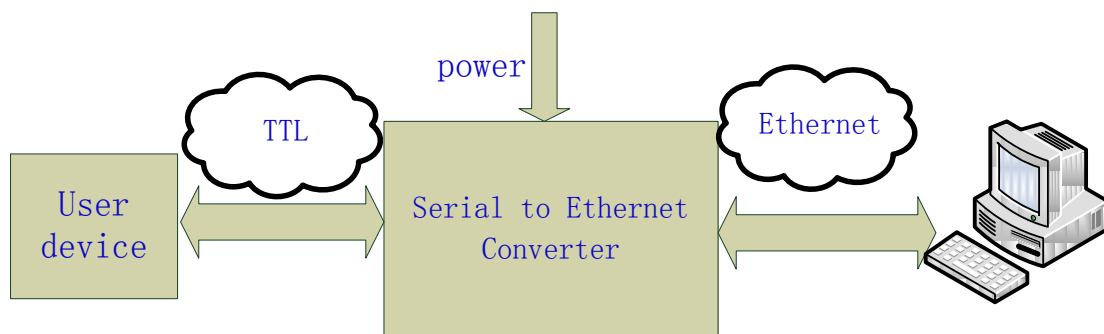

Take USB-TCP232-T for example, show demo application of module USB-TCP232-T

4.2 TCP Client Mode

In TCP client mode, after power on module according to their own Settings active TCP server to connect to the server, and then establish a long connection, data transparent transmission after this mode, the TCP server IP module would need to be visible and the visible means directly by module's IP can PING the server IP, server side can be fixed IP, the Internet can also be internal network IP and module in the same local area network.

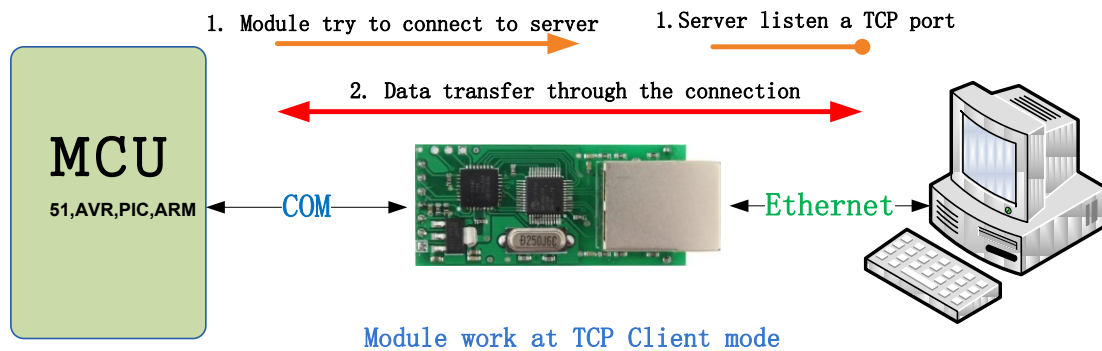

4.3 UDP Mode

In UDP mode, after the module is powered on listening on port Settings, not take the initiative to establish a connection, when data from by forwarding to the serial port, when a serial port receives the data sent over the network to the IP and port module Settings.

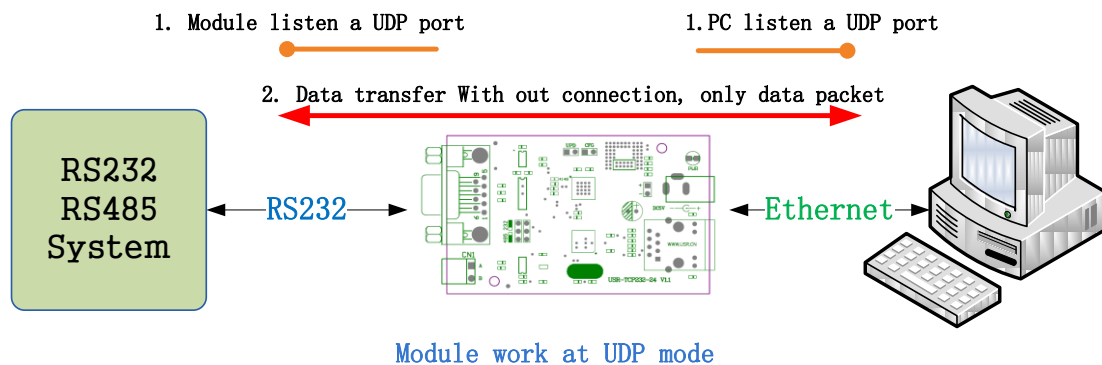

4.4 UDP Server Mode

UDP server refers to the normal UDP are not validated on the basis of the source IP address, destination

IP instead of the UDP packets are received data source IP, similar to TCP server functionality.

In this mode, the module by default record a destination IP, when a serial port data, to record the IP to send data, at the same time, the module at the server status, to accept the network packets sent to module, and adjust the target IP IP for the data source, suitable for multiple IP working mode for the module.

Use computer end program and UDP mode is exactly the same, no need to change.

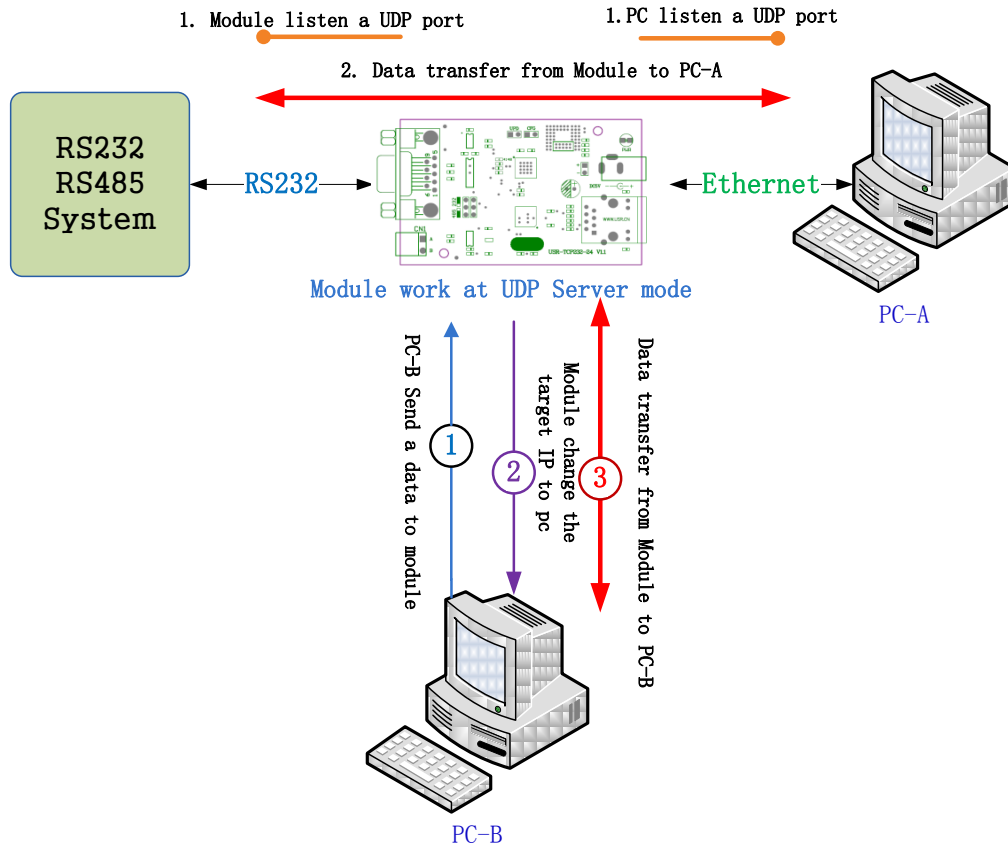

Note:UDP mode, UDP server mode with a single maximum length of 1472 bytes should be controlled at or below, if greater than this length, the module will automatically restart, the proposed subcontractor sent.

4.5 TCP Server Mode

In TCP Server mode, module and gateway trying to communication first, and then monitor set up local port, there is connection request response and create a connection, can exist at the same time up to 4 links, a serial port after receipt of the data will be sent to all at the same time of establishing links with network module device.

USR-TCP232-SETUP software, set the Index function can be achieved when to establish a multi-channel connection, the module can identify communications equipment, and with the specified device to communicate.

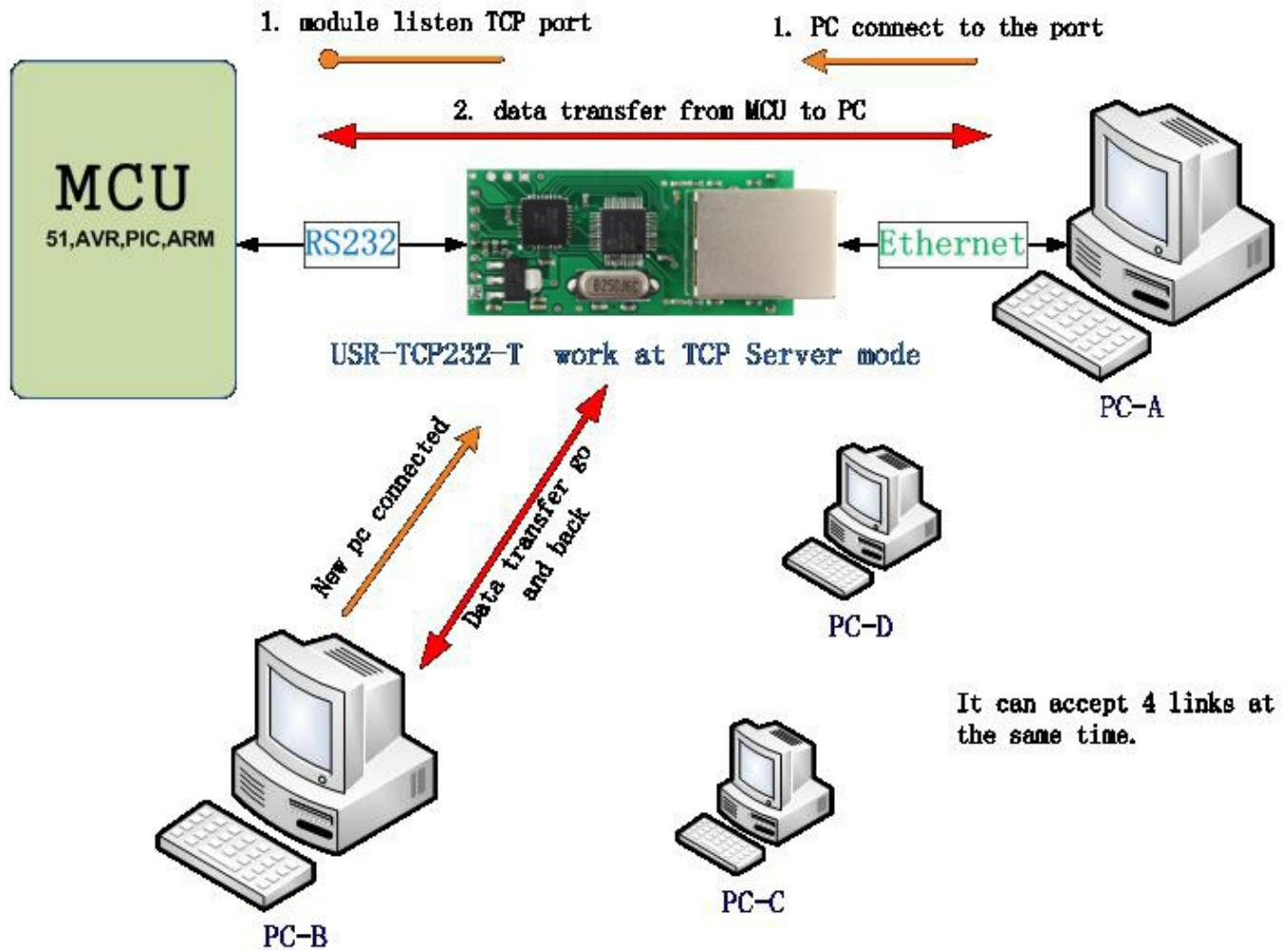

4.6 Special Functions

4.6.1 RS485

USR-TCP232-S, USR-TCP232-T, USR-TCP232-D products "RTS" Alternate Pin USR-TCP232-200 product "EN" alternate pin for RS485, external enable control pin.

Set the software interface:

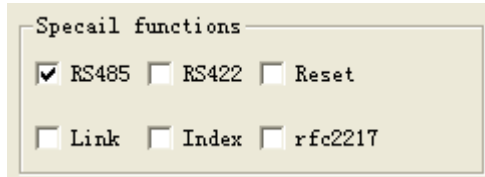

Specail functions

RS485 RS422 Reset

Link Index rfc2217

4.62 Link

The Link pins for the module to establish a communication connection status indicates pin, establish the communication Link pin will output low level, no connection is established, output high level.

USR-TCP232-S "CTS" Alternate Pin USR-TCP232-T products, USR-TCP232-200 product "Link" alternate pin, external Link instructions.

Set the software interface:

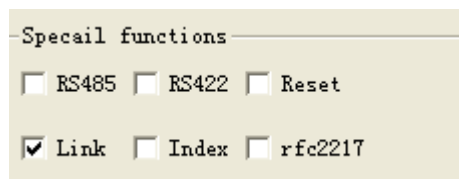

Specail functions

RS485 RS422 Reset

Link Index rfc2217

4.63 Reset

When the module as a TCP Client-side, the module will take the initiative to connect TCP SERVER. When the Reset function, the module tries to connect to TCP Server-side 30 times, still unable to establish a connection, the module will automatically restart.

Set the software interface:

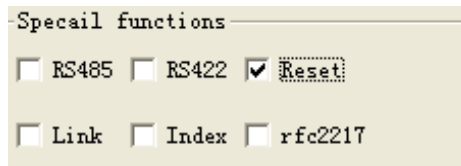

Specail functions

RS485 RS422 Reset

Link Index rfc2217

4.64 ID

Module as TCP Client-side ID function for TCP Server-side distinguish between data sources, to achieve the establishment of the connection or data communication process device ID will also be sent, the module ID number is set to decimal, range 0 - 65535, requires the receiving end HEX format.

1.Select "Connect" to establish a communication connection, TCP Server-side will receive the corresponding TCP Client-side ID (ID Description: The first four shows for the ID number, the last four digits of the display ID negated to authentication).

The following picture shows the module do TCP CLINENT establish a communication connection ID feature is enabled, the setup interface module ID number 12::

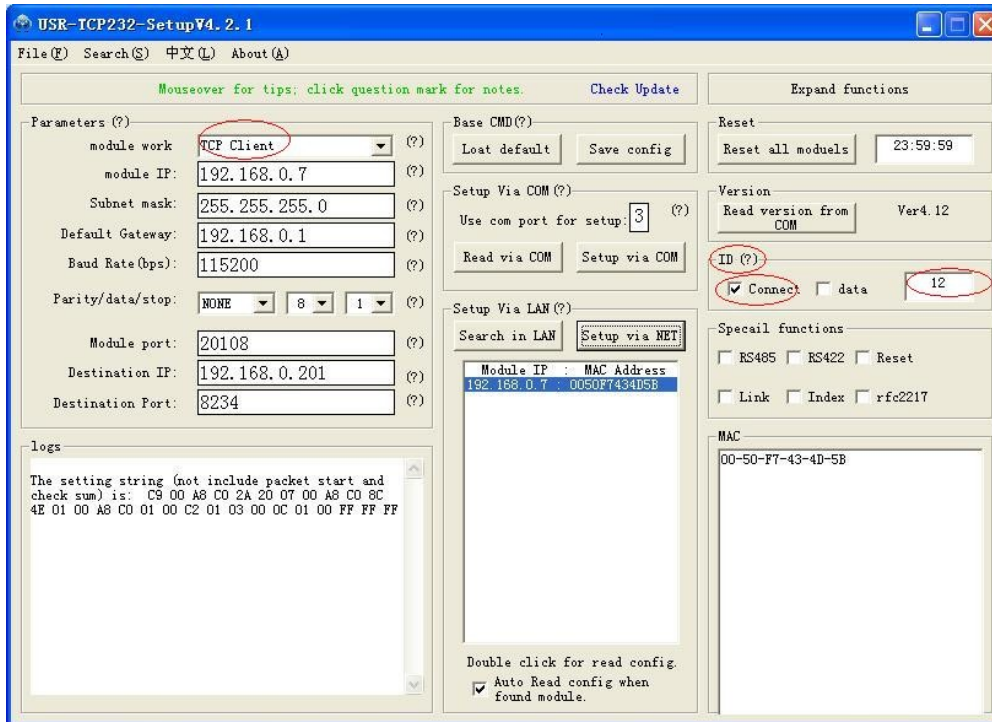

The figure below shows establish a communication connection ID function, the device through the serial communication interface to the TCP Server-side:

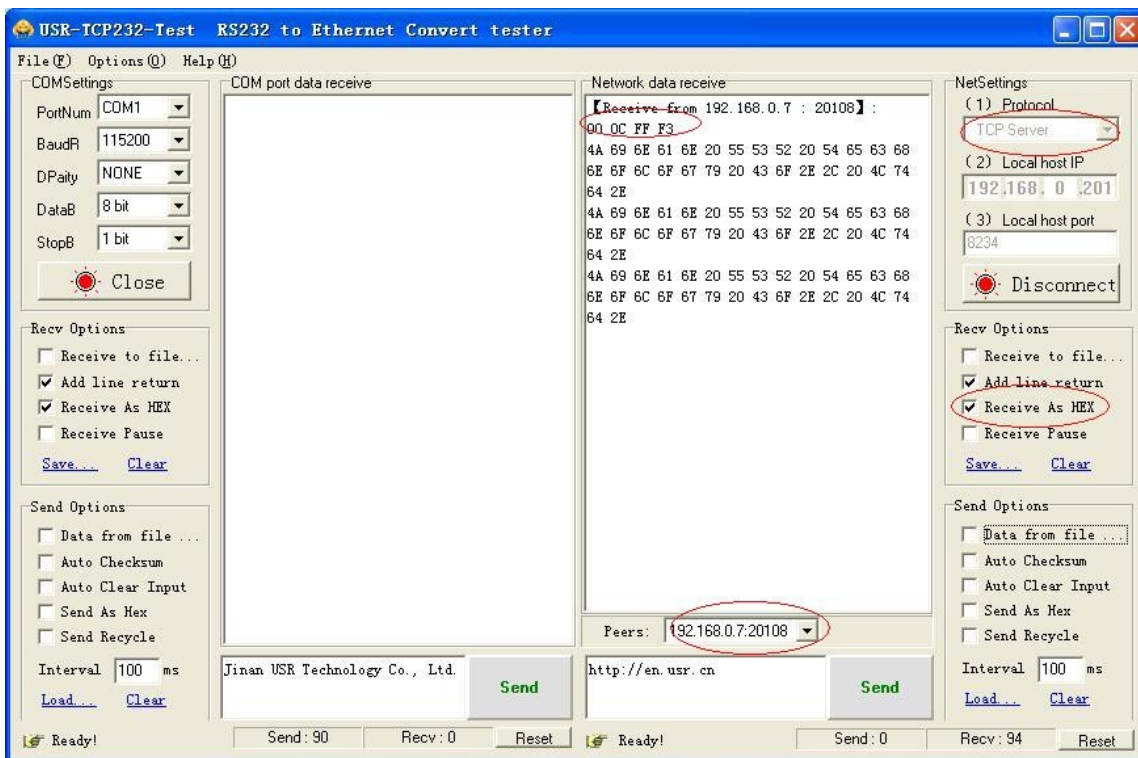

2. Select data during each data transfer, TCP Server-side will receive the corresponding TCP Client-side ID (ID Description: ID before data transmitted only display four-digit ID number).

The following picture shows the module do the TCP CLINENT ID feature is enabled, data transmission module ID number 12 setting interface:

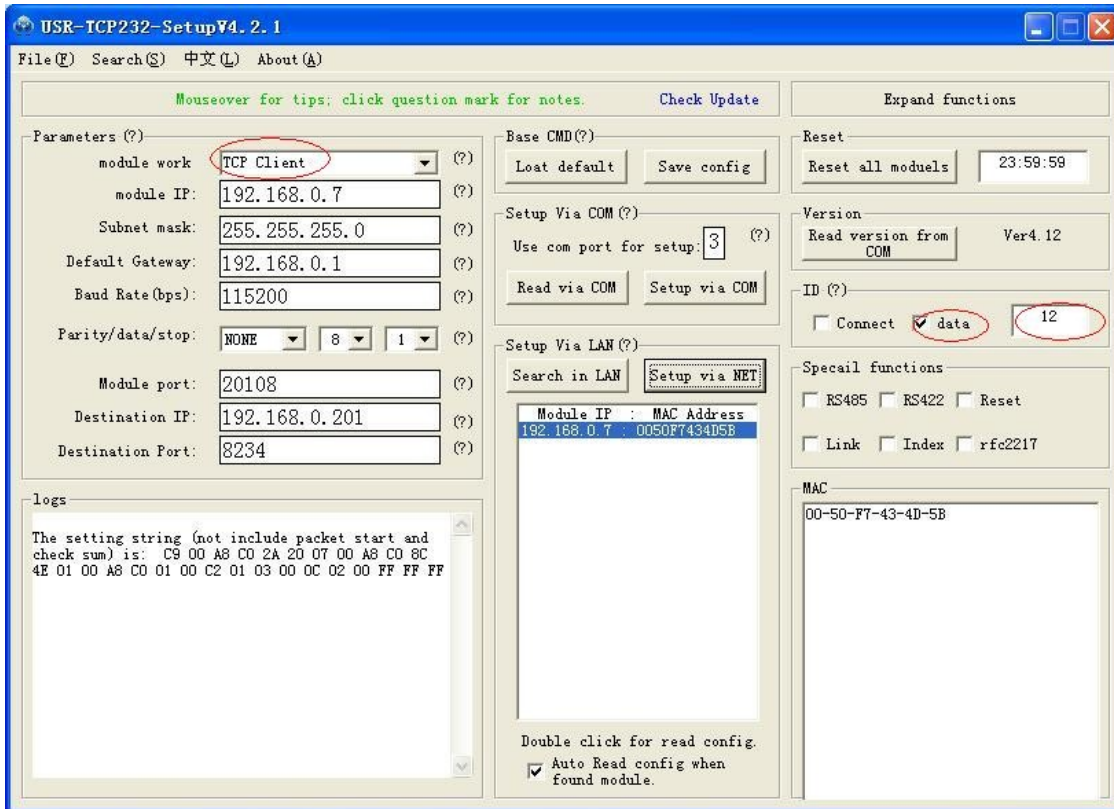

The figure below shows the data communication ID function, the device through the serial port to TCP Server communication interface:

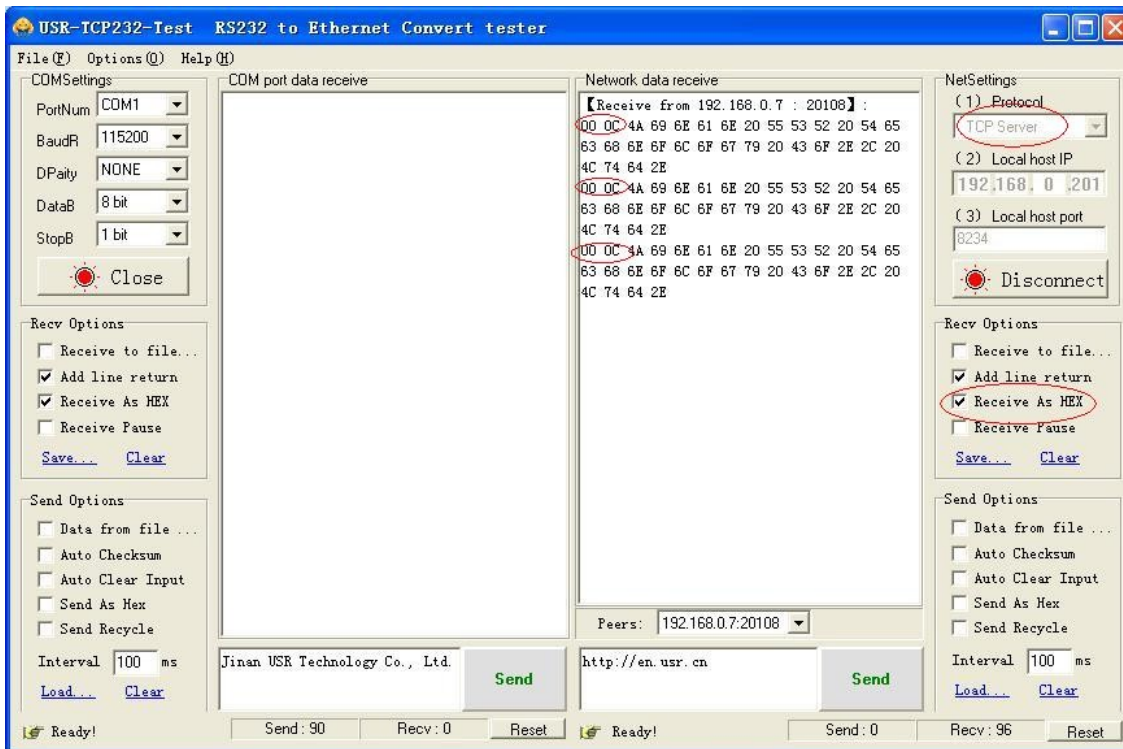

4.65 Index

Module as TCP SERVER end up at the same time to establish four connections, server-side at the same time send data to four CLIENT and SERVER the receiving Client-side data can not distinguish between sources of data, the Index function can send and receive data source selection.

Index function is enabled, communication data is displayed corresponding Client side device number, specific parameters are described below:

1. When receive data from Ethernet, module will send data to serial port with head 49 N, followed by data. 49 represent incoming data, N represent client index.

2. When user MCU want send data to module serial port, start with head 4F N data... 4F represent send out, N represent which client.

3. When new TCP connection incoming, module will send 43 N M to serial port, indicating that there is current link N accessed, total link number M.

4. When link number have exceed maximum, new link requirement will lead to message 46 46.

5. When disconnect, module will send 44 N M, represent current link N is delete, left link M.

Note: The above values set are HEX format.

Set the software interface:

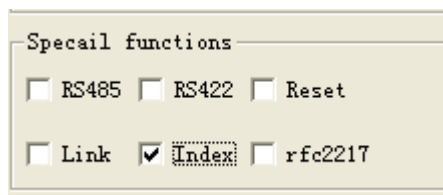

Data transmission as shown below:

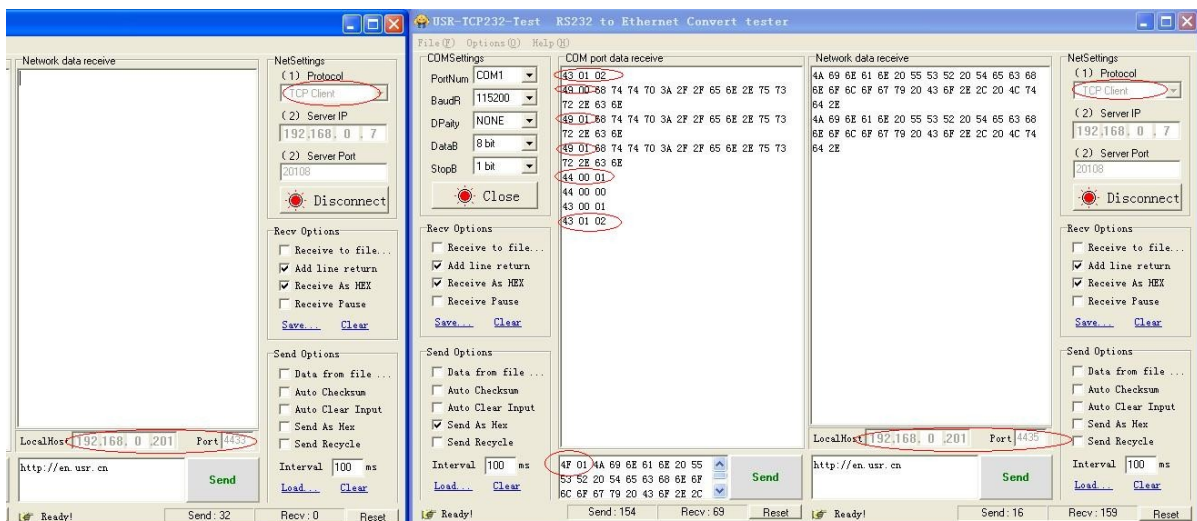

4.66 RFC2217

RFC2217 is an agreement for setup com port settings via Ethernet by socket, Our product support an agreement like that, but not standard RFC2217, it is more sample and easy than RFC2217.

1. When module receive setup command, if is a valid command(right packet head and right checksum), the module will change self setting and answer nothing, else the data bits would be sent out at com port.

2. TCP Client, TCP Server, UDP Client, UDP Server, UDP broadcast support this function.

3. All changes will work at once, but not save to module, when power off will lose the settings.

Set the software interface:

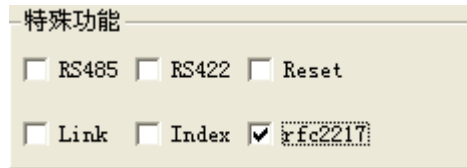

特殊功能

RS485 RS422 Reset

Link Index RFC2217

The command length is 8 bits, detail as follow table. The demo bytes are in hex mode:

Name	Packet header	Band rate	UART bits setting	Check sum
Bytes	3	3	1	1
Description	Three bytes	Band rate in hex mode, High byte first.	Parity/data/stop settings, see follow table.	Check sum of last 4 bytes
For example (115200,N,8,1)	55 AA 55	01 C2 00	83	83
For example (9600,N,8,1)	55 AA 55	00 25 80	83	83

Appendix: UART bits setting detail.

Bit	Description	Value	Description
1:0	Data bits	00	5 bits
		01	6 bits
		10	7 bits
		11	8 bits
2	Stop bits	0	1 bits
		1	2 bits
3	Parity enable	0	Not enable Parity
		1	Enable Parity
5:4	Parity type	00	ODD
		01	EVEN
		10	Mark
		11	Clear
8:6	Not used	000	Please fill 0

Test bits

55AA5501C2008346 For 115200 N,8,1

55AA550025808328 For 9600 N,8,1

Those two data is not transferred to serial, but the packet not conform will be transferred and revealed.



Open this function then open RFC2217 via USR-VCOM so serial port baud rate of PC application software serial server device can be matched automatically.

5. Application

5.1 COM TCP/UDP server

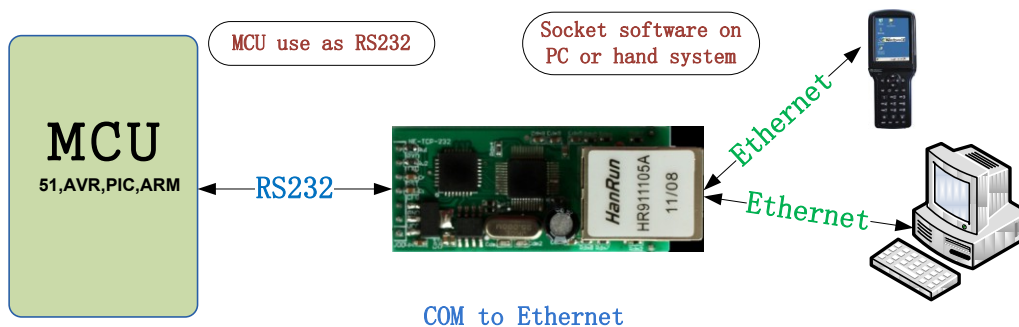

5.2 Virtual COM

Install USR-VCOM and make settings.

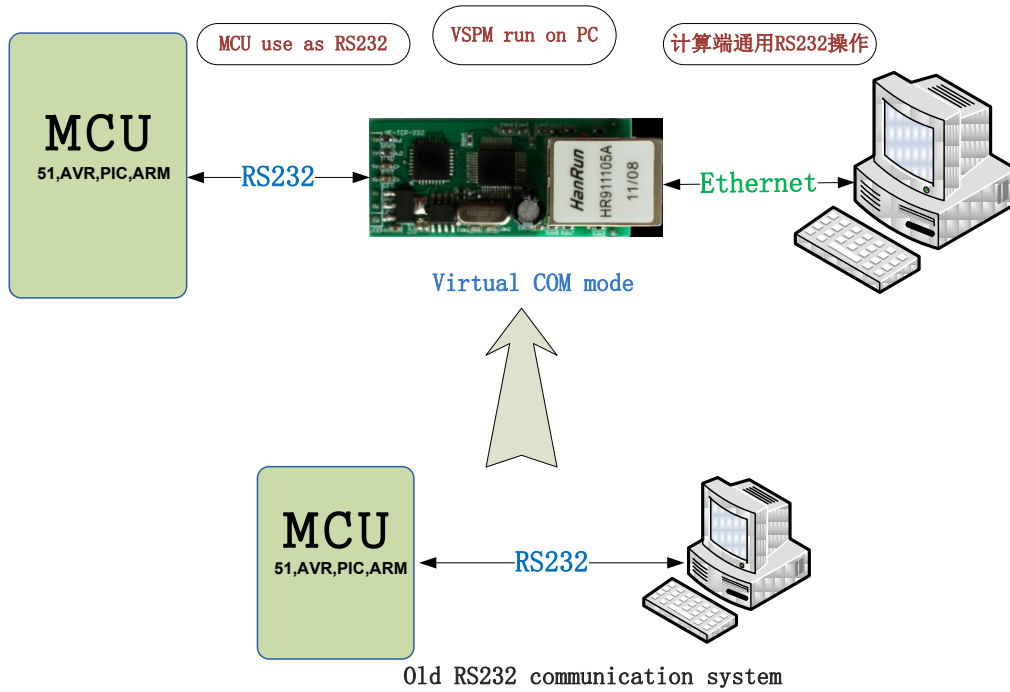

5.3 COM TCP/UDP COM

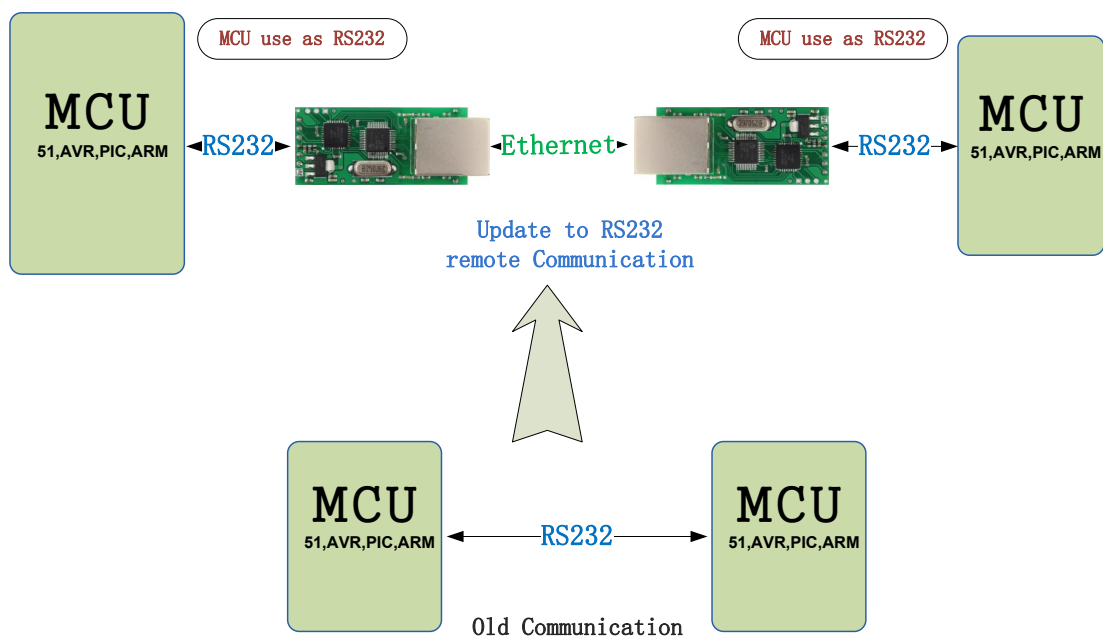

5.4 Many UDP server

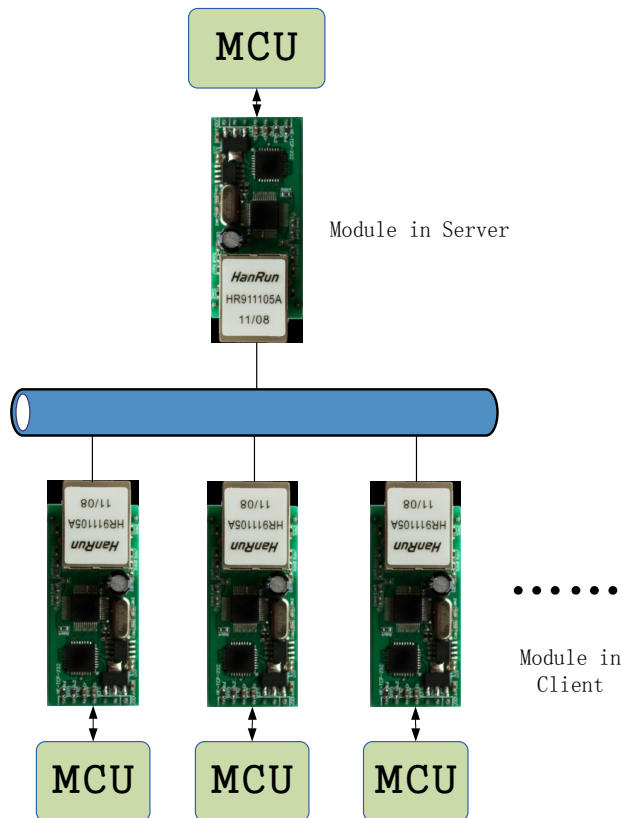

5.5 TCP/UDP proxy server

You can use a proxy server to treat the data form one module to other, or just use you MCU to control the module IP and destination IP Real-time. The method is pull CFG PIN to GND, and send the new configuration data, then pull CFG pin to VCC to use new settings.

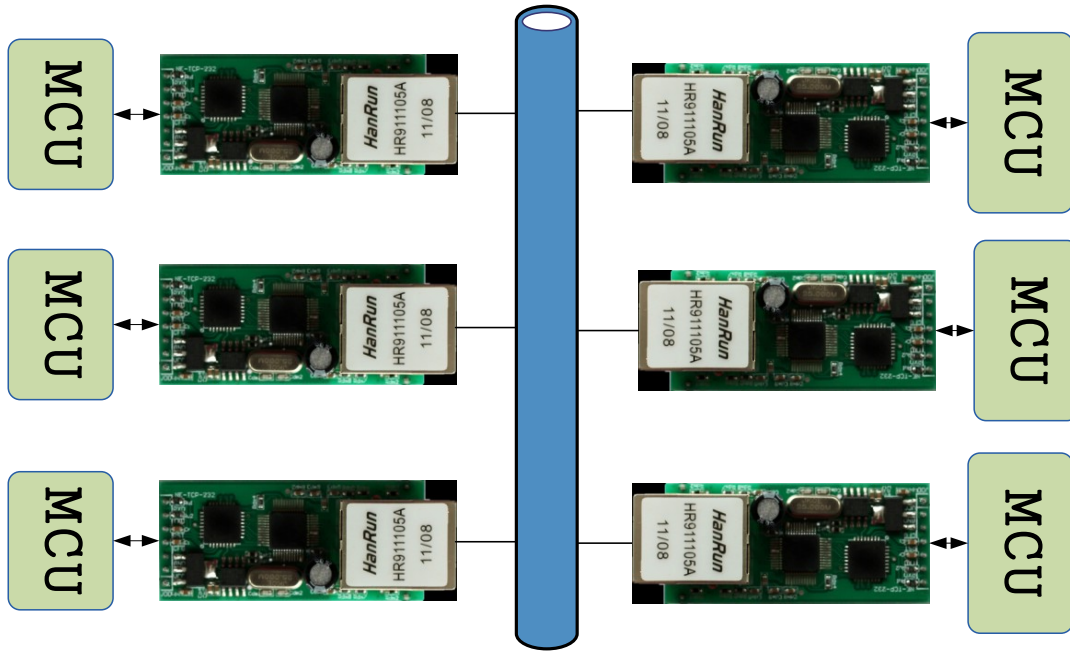

5.6 TCP/UDP server

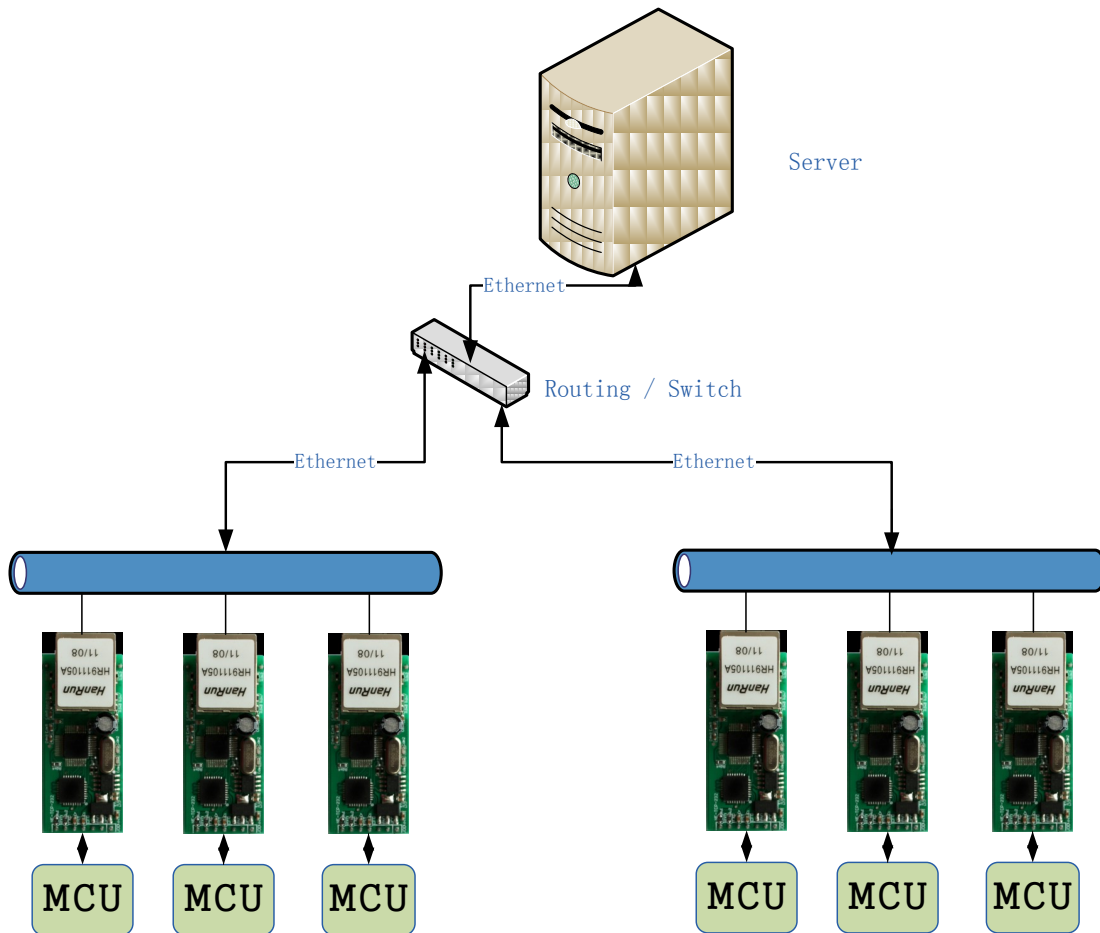

6. Configuration

Module's working mode can be set as needed, we try my best to let the user work become simple, all did not open advanced parameters, if you have special requirements, please contact us.

You can set the work mode, the module IP and port, subnet mask, gateway, serial port baud rate, module port, destination IP and port, can be set through the serial port or network port are two ways to setup software (USR-TCP232-Setup).

6.1 Configure Command Format

6.1.1 Serial Settings Command

Configure mode UART interface: 9600bps,n,8,1

Part	Bytes	Description	Example	Hex
prefix	2	0x55 0xAA	0x55 0xAA	0x55 0xAA
destination IP	4	destination IP	192.168.0.2 01	0xC9 0x00 0xA8 0xC0
destination port	2	Destination port	8234	0x2A 0x20
Host IP	4	The IP module hold	192.168.0.7	0x07 0x00 0xA8 0xC0
Host port	2	TCP/UDP source port	20108	0x8C 0x4E
Gateway	4	Gateway IP	192.168.0.2 01	0xC9 0x00 0xA8 0xC0
Work mode	1	0x01: TCP Client 0x00: UDP 0x02: UDP Server	TCP mode	0x01
baud rate	3	UART baud rate	115200	0x00 0xC2 0x01
Reserved	1	Reserved	00	0x00
checksum	1	Sum(destination IP, destination port, host IP, host port, gateway, work mode, baud rate, reserved)	0xB9	0xB9
prefix	2	0x55 0xAA	0x55 0xAA	0x55 0xAA

Once in configure mode, the UART parameter change to 9600bps,n,8,1, and a 'U' ascii character is send out to ensure the control MCU that in the configure mode. If the 24byte command has effect, a 'K' ascii character is send back to control MCU. If configure command format error, an 'E' character will be send back to control MCU. If the error is the checksum not match , the 1byte right checksum will be send back to control MCU also.

6.12 Network Settings Command

Network Settings is fulfilled via UDP Broadcast. No need and must not connect CFG.

UDP settings parameters:

UDP Broadcast Destination Address: 255.255.255.255

UDP Local Port: 1500

UDP Destination Port: 1500

40 bytes packet is broad-casted to the web via UDP when searching for devices. The module with same WLAN physically respond and return 35 bytes.

Send Settings Command Format:

Name	Length	Description	Example
MAC	6	Set MAC address of module	00 CE 83 25 4D 60
Old Password	6	110415	31 31 30 34 31 35
Configuration Parameter	21	It is same with serial settings excel, besides header and check bits.	c9 00 a8 c0 2a 20 07 00 a8 c0 8c 4e c9 00 a8 c0 01 00 c2 01 03
Independent ID	3	ID-H,ID-L,ID-type, 0 for not enable	00 00 00
Subnet Mask	4	The low is ahead, as 255.255.255.0	00 FF FF FF

Return Settings Command Format:

Name	Length	Description	Example
MAC	6	Set MAC address of module	00 CE 83 25 4D 60
Status Word	1	Version #, as 4.2 stands for 0x42	42
Configuration Parameter	21	It is same with serial settings excel, besides header and check bits.	C9 00 A8 C0 2A 20 07 00 A8 C0 8C 4E C9 00 A8 C0 01 00 C2 01 03
Independent ID	3	ID-H,ID-L,ID-type, 0 for not enable	00 00 00
Subnet Mask	4	The low is ahead, as255.255.255.0	00 FF FF FF

6.2 USR-TCP232-SETUP



USR - TCP232 - the Setup software can be extended in functions to specific function module Settings, as shown in the figure below.

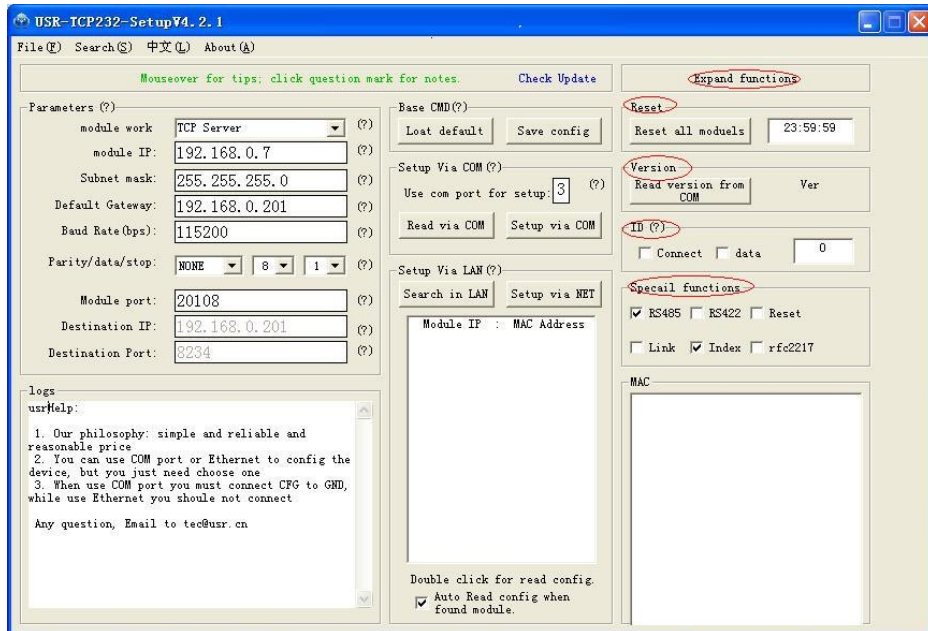

6.21 Setup via COM

In normal working condition, connect CFG pin to enter the serial configuration state, through the network configuration to be disconnect CFG pin module set through the serial port to receive instruction and to change the operating parameters.USR-TCP232-Setup software to be modified, as follows:

1. In "use com port for setup" fill in the correct COM number;
2. Click "read via com", the left side will display the current configuration parameters, can modify the parameters of the desired Settings;
3. Click "setup via com", to complete the module configuration;
4. After Setting, disconnect CFG, module begin work.

6.22 Setup via Net

Run USR-TCP232-Setup software then:

1. Click "search in LAN"
2. It reveals modules searched, double click, the left side will display the current configuration parameters, can modify the parameters of the desired Settings
3. Click "Setup via Net"
4. Module restart automatically

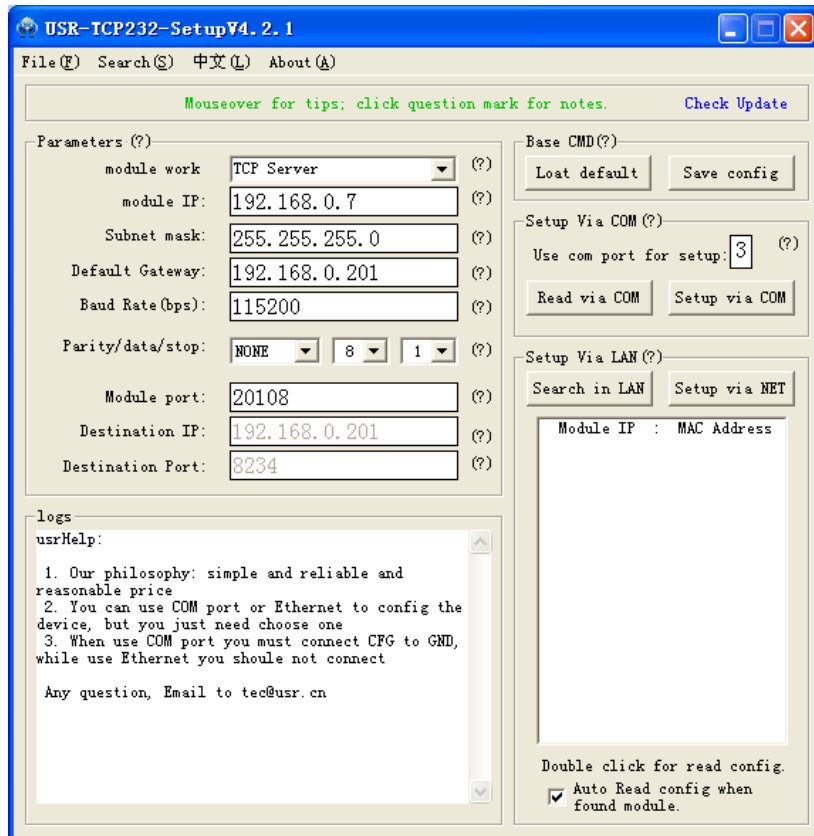

6.23 Special Function Configuration

USR - TCP232 - the Setup software can be extended in functions to specific function module Settings, as shown in the figure below.

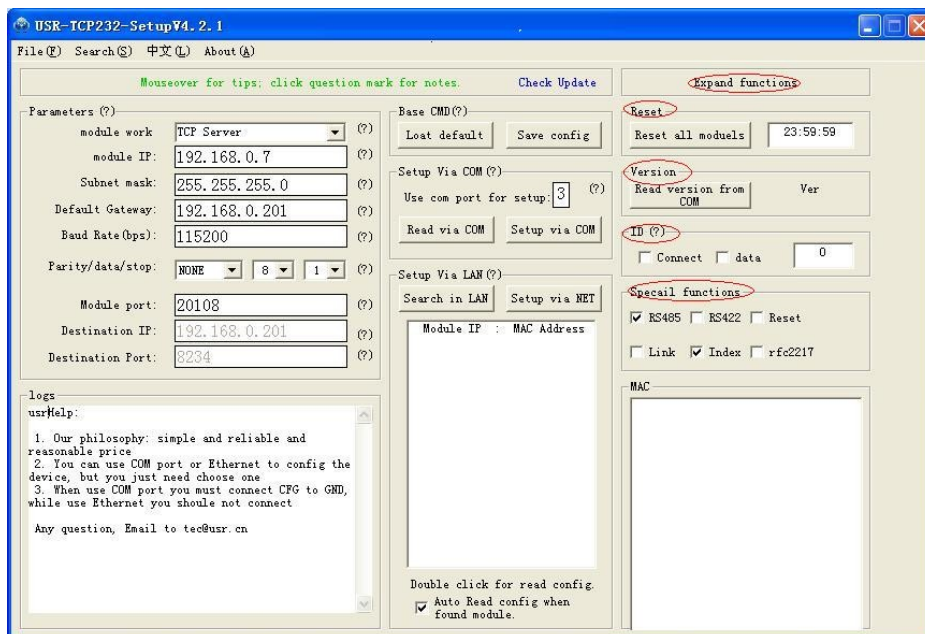

7. Contact us

Company: Jinan USR IOT Technology Limited
Address: Floor 11,Building1,No.1166 Xinluo Street,Gaoxin Distric,Jinan,Shandong,250101 China
Tel: 86-531-55507297, 86-531-88826739
Web: <http://www.usriot.com>
Support : <http://h.usriot.com>
Email: sales@usr.cn

Revision history

V3.2.2 Modify description about RS232 and RS485 selection jumper

V3.2.3 Remove Order Info

V3.2.4 Increase USR-TCP232-204

V3.2.5 Address